

Positive Displacement Pumps— Reciprocating

API STANDARD 674
SECOND EDITION, JUNE 1995

American Petroleum Institute
1220 L Street, Northwest
Washington, D.C. 20005



Positive Displacement Pumps— Reciprocating

Manufacturing, Distribution and Marketing Department

API STANDARD 674

SECOND EDITION, JUNE 1995

**American
Petroleum
Institute**



SPECIAL NOTES

1. API PUBLICATIONS NECESSARILY ADDRESS PROBLEMS OF A GENERAL NATURE. WITH RESPECT TO PARTICULAR CIRCUMSTANCES, LOCAL, STATE, AND FEDERAL LAWS AND REGULATIONS SHOULD BE REVIEWED.
2. API IS NOT UNDERTAKING TO MEET THE DUTIES OF EMPLOYERS, MANUFACTURERS, OR SUPPLIERS TO WARN AND PROPERLY TRAIN AND EQUIP THEIR EMPLOYEES, AND OTHERS EXPOSED, CONCERNING HEALTH AND SAFETY RISKS AND PRECAUTIONS, NOR UNDERTAKING THEIR OBLIGATIONS UNDER LOCAL, STATE, OR FEDERAL LAWS.
3. INFORMATION CONCERNING SAFETY AND HEALTH RISKS AND PROPER PRECAUTIONS WITH RESPECT TO PARTICULAR MATERIALS AND CONDITIONS SHOULD BE OBTAINED FROM THE EMPLOYER, THE MANUFACTURER OR SUPPLIER OF THAT MATERIAL, OR THE MATERIAL SAFETY DATA SHEET.
4. NOTHING CONTAINED IN ANY API PUBLICATION IS TO BE CONSTRUED AS GRANTING ANY RIGHT, BY IMPLICATION OR OTHERWISE, FOR THE MANUFACTURE, SALE, OR USE OF ANY METHOD, APPARATUS, OR PRODUCT COVERED BY LETTERS PATENT. NEITHER SHOULD ANYTHING CONTAINED IN THE PUBLICATION BE CONSTRUED AS INSURING ANYONE AGAINST LIABILITY FOR INFRINGEMENT OF LETTERS PATENT.
5. GENERALLY, API STANDARDS ARE REVIEWED AND REVISED, REAFFIRMED, OR WITHDRAWN AT LEAST EVERY FIVE YEARS. SOMETIMES A ONE-TIME EXTENSION OF UP TO TWO YEARS WILL BE ADDED TO THIS REVIEW CYCLE. THIS PUBLICATION WILL NO LONGER BE IN EFFECT FIVE YEARS AFTER ITS PUBLICATION DATE AS AN OPERATIVE API STANDARD OR, WHERE AN EXTENSION HAS BEEN GRANTED, UPON REPUBLICATION. STATUS OF THE PUBLICATION CAN BE ASCERTAINED FROM THE API AUTHORIZING DEPARTMENT [TELEPHONE (202) 682-8000]. A CATALOG OF API PUBLICATIONS AND MATERIALS IS PUBLISHED ANNUALLY AND UPDATED QUARTERLY BY API, 1220 L STREET, N.W., WASHINGTON, D.C. 20005.

FOREWORD

This standard is based on the accumulated knowledge and experience of manufacturers and users of reciprocating positive displacement pumps. The objective of this standard is to provide a purchase specification to facilitate the manufacture and procurement of reciprocating positive displacement pumps for use in petroleum, chemical, and gas industry services.

The primary purpose of this standard is to establish minimum mechanical requirements. This limitation in scope is one of charter as opposed to interest and concern. Energy conservation is of concern and has become increasingly important in all aspects of equipment design, application, and operation. Thus, innovative energy-conserving approaches should be aggressively pursued by the manufacturer and the user during these steps. Alternative approaches that may result in improved energy utilization should be thoroughly investigated and brought forth. This is especially true of new equipment proposals, since the evaluation of purchase options will be based increasingly on total life costs as opposed to acquisition cost alone. Equipment manufacturers, in particular, are encouraged to suggest alternatives to those specified when such approaches achieve improved energy effectiveness and reduced total life costs without sacrifice of safety or reliability.

This standard requires the purchaser to specify certain details and features. Although it is recognized that the purchaser may desire to modify, delete, or amplify sections of this standard, it is strongly recommended that such modifications, deletions, and amplifications be made by supplementing this standard, rather than by rewriting or incorporating sections thereof into another complete standard.

API standards are published as an aid to procurement of standardized equipment and materials. These standards are not intended to inhibit purchasers or producers from purchasing or producing products made to other standards.

API publications may be used by anyone desiring to do so. Every effort has been made by the Institute to assure the accuracy and reliability of the data contained in them; however, the Institute makes no representation, warranty, or guarantee in connection with this publication and hereby expressly disclaims any liability or responsibility for loss or damage resulting from its use or for the violation of any federal, state, or municipal regulation with which this publication may conflict.

Suggested revisions are invited and should be submitted to the director of the Manufacturing, Distribution and Marketing Department, American Petroleum Institute, 1220 L Street, N.W., Washington, D.C. 20005.

CONTENTS

	Page
SECTION 1—GENERAL	
1.1 Scope.....	1
1.2 Alternative Designs	1
1.3 Conflicting Requirements.....	1
1.4 Definition of Terms.....	1
1.5 Referenced Publications	2
1.6 Unit Conversion.....	4
 SECTION 2—BASIC DESIGN	
2.1 General.....	5
2.2 Selection of Types.....	5
2.3 Ratings	5
2.4 Cylinders and Pressure-Retaining Parts (Including Pulsation Suppression Devices).....	7
2.5 Cylinder Connections	8
2.6 Liquid End Appurtenances	9
2.7 Power End Running Gear	10
2.8 Gas End, Direct-Acting Pump	10
2.9 Lubrication.....	11
2.10 Materials	12
2.11 Nameplates and Rotation Arrows	15
2.12 Quality	15
 SECTION 3—ACCESSORIES	
3.1 Drivers	16
3.2 Couplings and Guards.....	17
3.3 Mounting Plates.....	17
3.4 Controls and Instrumentation	19
3.5 Piping.....	22
3.6 Pulsation and Vibration Control Requirements.....	25
3.7 Special Tools.....	27
 SECTION 4—INSPECTION, TESTING, AND PREPARATION FOR SHIPMENT	
4.1 General.....	27
4.2 Inspection.....	27
4.3 Tests	28
4.4 Preparation for Shipment.....	29
 SECTION 5—VENDOR'S DATA	
5.1 General.....	30
5.2 Proposals.....	31
5.3 Contract Data	32
 APPENDIX A—RECIPROCATING PUMP DATA SHEETS	
33	
APPENDIX B—MATERIALS AND MATERIAL SPECIFICATIONS	
FOR MAJOR COMPONENT PARTS.....	
45	
APPENDIX C—INSPECTOR'S CHECKLIST.....	
51	
APPENDIX D—VENDOR DRAWING AND DATA REQUIREMENTS	
55	
APPENDIX E—PULSATION CONTROL TECHNIQUES	
61	

	Page
APPENDIX F—GUIDELINE FOR PUMP PIPING DESIGN AND PREPARATION FOR AN ACOUSTICAL SIMULATION ANALYSIS	63
APPENDIX G—NET POSITIVE SUCTION HEAD VERSUS NET POSITIVE INLET PRESSURE.....	65
 Figures	
1—Viscosity Correction to Maximum Allowable Speed Rating	7
2—Baseplate Mounting Pad Arrangement	18
3—Suction	26
4—Discharge.....	26
 Tables	
1—Maximum Allowable Speed Ratings for Power Pumps in Continuous Service	6
2—Maximum Allowable Speed Ratings for Direct-Acting Pumps in Continuous Service	6
3—Conditions Requiring Alarms and Shutdowns.....	21
4—Minimum Requirements for Piping Materials	24
5—Maximum Severity of Defects in Castings	28
B-1—Materials for Reciprocating Pump Liquid End Parts	47
B-2—Materials for Direct-Acting Reciprocating Pump Gas End Parts	48
B-3—Material Specifications for Reciprocating Pump Parts	49
F-1—Information From the Pump Vendor.....	64

Positive Displacement Pumps—Reciprocating

SECTION 1—GENERAL

1.1 Scope

This standard covers the minimum requirements for reciprocating positive displacement pumps for use in service in the petroleum, chemical, and gas industries. Both direct-acting and power-frame types are included. See API Standard 675 for controlled-volume pumps and Standard 676 for rotary pumps.

Note: A bullet (●) at the beginning of a paragraph indicates that either a decision is required or further information is to be provided by the purchaser. This information should be indicated on the data sheets (see Appendix A); otherwise, it should be stated in the quotation request or in the order.

1.2 Alternative Designs

The vendor may offer alternative designs. Equivalent metric dimensions, fasteners, and flanges may be substituted as mutually agreed upon by the purchaser and the vendor.

1.3 Conflicting Requirements

In case of conflict between this standard and the inquiry or order, the information included in the order shall govern.

1.4 Definition of Terms

Terms used in this standard are defined in 1.4.1 through 1.4.25.

1.4.1 *Alarm point* is a preset value of a parameter at which an alarm is activated to warn of a condition requiring corrective action.

1.4.2 A *direct-acting pump* is a reciprocating pump consisting of a piston-powered drive end connected directly to a liquid end. Power is directly transmitted to the liquid end by the action of the motive fluid on the piston. A direct-acting pump may use steam, air, or gas as the motive fluid.

1.4.3 *Gauge board* is an unenclosed bracket or plate used to support and display gauges, switches, and other instruments.

1.4.4 *Local* means mounted on, or in close proximity to, the equipment.

1.4.5 *Maximum allowable speed* (in revolutions per minute for single-acting pumps and strokes per minute for double-acting pumps) is the highest speed at which the manufacturer's design will permit continuous operation.

1.4.6 *Maximum allowable temperature* is the maximum continuous temperature for which the manufacturer has

designed the equipment (or any part to which the term is applied) when handling the specified fluid at the specified pressure.

1.4.7 *Maximum allowable working pressure* is the maximum continuous pressure for which the manufacturer has designed the equipment (or any part to which the term is applied) when handling the specified fluid at the specified temperature and capacity.

1.4.8 *Minimum allowable speed* (in revolutions per minute) is the lowest speed at which the manufacturer's design will permit continuous operation.

1.4.9 *Minimum allowable temperature* is the minimum continuous temperature for which the manufacturer has designed the equipment (or any part to which the term is applied).

1.4.10 *Net positive suction head (NPSH)* is the total inlet pressure, in meters (feet), determined at the pump suction connection, minus the vapor pressure of the liquid in meters (feet).

1.4.11 *Net positive suction head available (NPSHA)* is the NPSH, in meters (feet), minus the preliminary anticipated system acceleration head, determined by the purchaser for the pumping system at the pump inlet flange with the fluid at the rated capacity and normal pumping temperature.

Note: Selected equipment and final piping acoustic layout will dictate final acceleration head and resulting NPSHA. See Appendix G for a discussion of NPSHA and Net Positive Inlet Pressure (NPIP).

1.4.12 *Net positive suction head required (NPSHR)* is the NPSH in meters (feet), including acceleration head, determined by vendor testing, usually with water. NPSHR is measured at the suction flange. NPSHR is the minimum NPSH at rated capacity required to prevent more than three percent capacity drop due to cavitation within the pump.

1.4.13 *Piston or plunger load* is the force acting on one plunger or piston during any portion of the pumping cycle.

1.4.14 A *power pump* is a reciprocating pump consisting of a power end and a liquid end connected by a frame or distance piece. The power end is a mechanism that transmits energy from a rotating shaft to pistons or plungers by means of a crankshaft, crossheads, and connecting rods. The liquid end consists of the cylinders, the pistons or plungers, and the valves.

1.4.15 A *panel* is an enclosure used to mount, display, and protect gauges, switches, and other instruments.

1.4.16 *Preliminary anticipated system acceleration head* is the estimated pressure change due to changes in velocity in the piping system. It is an important factor in the application of reciprocating pumps because of the pulsating nature of the flow in the pump suction line.

Note: For additional information on acceleration head, refer to Hydraulic Institute standards (1.5.3).

1.4.17 A *pressure-containing part* is a part that acts as a barrier between process or motive fluid and the atmosphere. Such parts include, but are not necessarily limited to the liquid cylinder, the discharge manifold, the suction manifold, the stuffing box, cylinder plugs and covers (when in contact with process fluid), valve seats (when a portion is in contact with the atmosphere), the gas cylinder, the gas cylinder head, the valve chest, and the valve chest cover and heads.

1.4.18 A *pressure-retaining part* is a part whose failure would allow process or motive fluid to escape to the atmosphere. In addition to the pressure-containing parts listed in 1.4.17, pressure-retaining parts include, but are not necessarily limited to, liquid and gas cylinder bolting, stuffing box bolting, gland bolting, glands, and covers that constrain plugs and valve stops. Not included in pressure-retaining parts are parts such as packing, gaskets, pistons, plungers, piston rings, rods, valves, seats (when completely surrounded by pressure-containing parts), and internal bolting.

1.4.19 *Pump efficiency* (also called *pump mechanical efficiency*) for power pumps is the ratio of the pump hydraulic power to the pump power input. *Pump efficiency for direct-acting pumps* is the ratio of the force exerted on the liquid by the liquid piston or plunger to the force exerted on the gas piston by the motive gas, neglecting all fluid friction losses through porting and valves.

1.4.20 *Rated capacity* of a reciprocating pump is the total volume of fluid actually delivered per unit of time at the stated operating conditions. Rated capacity includes liquid and any dissolved or entrained gases or solids, and is based on suction conditions.

1.4.21 *Rated discharge pressure* is the required discharge pressure of the pump at rated capacity, speed, suction pressure, specific gravity, and viscosity.

1.4.22 *Remote* means located away from the equipment or console, typically in a control house.

1.4.23 *Shutdown point* is a preset value of a parameter requiring automatic or manual shutdown of a system.

1.4.24 *Unit responsibility* refers to the responsibility for coordinating the technical aspects of the equipment and all auxiliary systems included in the scope of the order. It includes responsibility for such factors as the power requirements, speed, rotation, general arrangements, couplings, dynamics, noise, lubrication, sealing systems, material test reports, instrumentation, piping, and testing of components.

1.4.25 *Volumetric efficiency* is the ratio of the pump suction capacity to pump displacement and is expressed as a percentage.

1.4.26 The use of the word *design* in any term (such as design power, design pressure, design temperature, or design speed) should be avoided in the purchaser's specifications. This terminology should be used only by the equipment designer and the manufacturer.

1.5 Referenced Publications

1.5.1 This standard makes reference to American standards. Other international or national standards may be used as mutually agreed upon between purchaser and vendor provided it can be shown that these other standards meet or exceed the American standards referenced.

1.5.2 The editions of the following standards, codes, and specifications that are in effect at the time of publication of this standard shall, to the extent specified herein, form a part of this standard. The applicability of changes in standards, codes, and specifications that occur after the inquiry shall be mutually agreed upon by the purchaser and the vendor.

AFBMA¹

- Std 7 *Shaft and Housing Fits for Metric Radial Ball and Roller Bearings*
- Std 9 *Load Ratings and Fatigue Life for Ball Bearings*
- Std 11 *Load Ratings and Fatigue Life for Roller Bearings*
- Std 20 *Metric Ball and Roller Bearings (Except Tapered Roller Bearings) Conforming to Basic Boundary Plans*

AGMA²

- 6010-E88 *Standard for Spur, Helical, Herringbone, and Bevel Enclosed Drives*
- 6019-E89 *Gearmotors Using Spur, Helical, Herringbone, Straight Bevel or Spiral Bevel Gears*

API

- RP 500 *Classification of Locations for Electrical Installations at Petroleum Facilities*
- RP 520 *Sizing, Selection, and Installation of Pressure-Relieving Devices in Refineries, Part I—"Sizing and Selection" and Part II—"Installation"*
- RP 550 *Manual on Installation of Refinery Instruments and Control Systems* (out of print)
- RP 683 *Quality Improvement Manual for Mechanical Equipment in Petroleum, Chemical, and Gas Industries*

¹Anti-Friction Bearing Manufacturers Association, 1235 Jefferson Davis Highway, Arlington, Virginia 22202.

²American Gear Manufacturers Association, 1500 King Street, Suite 201, Alexandria, Virginia 22314-2730.

- Spec 5L *Specification for Line Pipe*
 Std 526 *Flanged Steel Safety-Relief Valves*
 Std 611 *General-Purpose Steam Turbines for Refinery Services*
 Std 612 *Special-Purpose Steam Turbines for Refinery Services*
 Std 613 *Special-Purpose Gear Units for Refinery Services*
 Std 614 *Lubrication, Shaft-Sealing, and Control-Oil Systems for Special-Purpose Applications*
 Std 615 *Sound Control of Mechanical Equipment for Refinery Services (out of print)*
 Std 618 *Reciprocating Compressors for General Refinery Services*
 Std 670 *Vibration, Axial-Position, and Bearing-Temperature Monitoring Systems*
 Std 671 *Special-Purpose Couplings for Refinery Services*
 Std 675 *Positive Displacement Pumps—Controlled Volume*
 Std 676 *Positive Displacement Pumps—Rotary*
 Std 677 *General-Purpose Gear Units for Refinery Services*
 Std 678 *Accelerometer-Based Vibration Monitoring System (out of print)*
- ASME³
- B1.1 *Unified Inch Screw Threads (UN and UNR Thread Form)*
 B1.20.1 *General Purpose (Inch) Pipe Threads*
 B16.1 *Cast Iron Pipe Flanges and Flanged Fittings, Class 25, 125, 250, and 800*
 B16.5 *Pipe Flanges and Flanged Fittings, Steel Nickel Alloy, and Other Special Alloys*
 B16.11 *Forged Steel Fittings, Socketwelding and Threaded*
 B16.42 *Ductile Iron Pipe Flanges and Flanged Fittings, Class 150 and 300*
 B16.47 *Large Diameter Steel Flanges: NPS 26 through NPS 60*
 B31.3 *Chemical Plant Petroleum Refinery Piping*
 Y14.2M *Line Conventions and Lettering*
Boiler and Pressure Vessel Code, Section V, "Nondestructive Examination"; Section VIII, "Rules for Construction of Pressure Vessels"; and Section IX, "Welding and Brazing Qualifications"
- ASTM⁴
- A 48 *Specification for Gray Iron Castings*
 A 105 *Specification for Carbon Steel Forgings for Piping Components*
 A 106 *Specification for Seamless Carbon Steel Pipe for High-Temperature Service*
 A 108 *Specification for Cold-Finished Carbon Steel Bars, Standard Quality*
 A 153 *Specification for Zinc Coating (Hot Dip) on Iron and Steel Hardware*
 A 181 *Specification for Carbon Steel Forgings for General Purpose Piping*
 A 182 *Specification for Forged or Rolled Alloy-Steel Pipe Flanges, Forged Fittings, and Valves and Parts for High-Temperature Service*
 A 192 *Specification for Seamless Carbon Steel Boiler Tubes for High-Pressure Service*
 A 193 *Specification for Alloy-Steel and Stainless Steel Bolting*
 A 194 *Specification for Carbon and Alloy Steel Nuts for Bolts for High-Pressure and High-Temperature Service*
 A 197 *Specification for Cupola Malleable Iron*
 A 216 *Specification for Carbon-Steel Castings Suitable for Fusion Welding for High-Temperature Service*
 A 217 *Specification for Martensitic Stainless Steel and Alloy Steel Castings for Pressure-Containing Parts Suitable for High-Temperature Service*
 A 247 *Method for Evaluating the Microstructure of Graphite in Iron Castings*
 A 269 *Specification for Seamless and Welded Austenitic Stainless Steel Tubing for General Service*
 A 276 *Specification for Stainless and Heat-Resisting Steel Bars and Shapes*
 A 278 *Specification for Gray Iron Castings for Pressure-Containing Parts for Temperatures up to 650°F (345°C)*
 A 296 *Specification for Corrosion-Resistant Iron-Chromium, Iron-Chromium-Nickel, and Nickel Base Alloy Castings for General Application*
 A 307 *Specification for Carbon Steel Bolts and Studs, 60,000 psi Tensile*
 A 312 *Specification for Seamless and Welded Austenitic Stainless Steel Pipe*
 A 320 *Specification for Alloy-Steel Bolting Materials for Low-Temperature Service*
 A 322 *Specification for Hot-Rolled Alloy Steel Bars*
 A 338 *Specification for Malleable Iron Flanges, Pipe Fittings, and Valve Parts for Railroad, Marine, and Other Heavy Duty Service at Temperatures up to 650°F (345°C)*

³American Society of Mechanical Engineers, 345 East 47th Street, New York, New York 10017.

⁴American Society of Testing and Materials, 1916 Race Street, Philadelphia, Pennsylvania 19103-1187.

- A 352 *Specification for Ferritic Steel Castings for Pressure-Containing Parts Suitable for Low-Temperature Service*
- A 395 *Specification for Ferritic Ductile Iron Pressure-Retaining Castings for Use at Elevated Temperatures*
- A 515 *Specification for Carbon Steel Pressure Vessel Plates for Intermediate- and Higher-Temperature Service*
- A 524 *Specification for Seamless Carbon Steel Pipe for Atmospheric and Lower Temperatures*
- A 536 *Specification for Ductile Iron Castings*
- A 582 *Specification for Hot-Rolled or Cold-Finished Free Machining Stainless and Heat-Resisting Steel Bars*
- B 124 *Specification for Copper and Copper Alloy Forging Rod, Bar, and Shapes*
- B 139 *Specification for Phosphor Bronze Rod, Bar, and Shapes*
- B 584 *Specification for Copper Alloy Sand Castings for Radiographic Testing*
- E 94 *Recommended Practice for Radiographic Testing*
- E 125 *Reference Photographs for Magnetic Particle Indications on Ferrous Castings*
- E 142 *Method for Controlling Quality of Radiographic Testing*
- E 709 *Practice for Magnetic Particle Examination*
- AWS⁵
- D1.1 *Structural Welding Code—Steel*
- ISO⁶
- 228 *Pipe Threads Where Pressure Tight Joints Are Not Made on the Threads, Part 1—*
- “Designation/Dimensions and Tolerances” and Part 2—“Verification by Means of Limit Gauges”
- NACE⁷
- MR-01-90 *Sulfide Stress Corrosion Cracking Resistant Metallic Material for Oil Field Equipment Corrosion Engineer’s Reference Book*
- NEMA⁸
- MG 1 *Motors and Generators*
- NFPA⁹
- 70 *National Electrical Code*
- TEMA¹⁰
- Standards for Tubular Exchanger Manufacturers Association*

1.5.3 The standards of the Hydraulic Institute¹¹ also form a part of this standard.

1.5.4 The purchaser and the vendor shall mutually determine the measures that must be taken to comply with any governmental codes, regulations, ordinances, or rules that are applicable to the equipment.

1.5.5 It is the vendor’s responsibility to invoke all applicable specifications to each subvendor.

1.6 Unit Conversions

The factors in Chapter 15 of the *API Manual of Petroleum Measurement Standards* were used to convert from U.S. Customary Units to metric units. The resulting exact metric units were then rounded off.

⁷National Association of Corrosion Engineers, P.O. Box 218340, Houston, Texas 77218. ⁸American Welding Society, 550 N.W. LeJeune Road, Miami, Florida 33135.

⁸National Electrical Manufacturers Association, 2101 L Street, NW, Washington, D.C. 20037.

⁹National Fire Protection Association, 1 Batterymarch Park, Quincy, Massachusetts 02269-9101.

¹⁰Tubular Exchangers Manufacturers Association, 25 North Broadway, Tarrytown, New York 10591.

¹¹The Hydraulic Institute, 9 Sylvan Way, Parsippany, New Jersey 07054-3802.

⁵American Welding Society, 550 N.W. LeJeune Road, Miami, Florida 33135.

⁶International Organization for Standardization. ISO publications are available from the American National Standards Institute, 11 West 42nd Street, New York, New York 10036.

SECTION 2—BASIC DESIGN

2.1 General

2.1.1 The equipment (including auxiliaries) covered by this standard shall be designed and constructed for minimum service life of 20 years and at least three years of uninterrupted operation. It is recognized that this is a design criterion.

2.1.2 The vendor shall assume unit responsibility for all equipment and all auxiliary systems included in the scope of the order.

● **2.1.3** The purchaser will specify the equipment's normal operating point (rated conditions) on the data sheets.

● **2.1.4** Control of the sound pressure level (SPL) of all equipment furnished shall be on a joint effort of the purchaser and the vendor. The equipment furnished by the vendor shall conform to the maximum allowable sound pressure level specified by the purchaser.

2.1.5 Unless otherwise specified, cooling water systems shall be in accordance with 2.1.5.1 and 2.1.5.2.

2.1.5.1 Cooling water systems shall be designed for the following conditions:

	SI Units	Customary Units
Velocity over heat exchange surfaces	1.5–2.5 m/s	5–8 f/s
Maximum allowable working pressure	5.2 bar (ga)	75 psig
Test pressure	7.9 bar (ga)	115 psig
Maximum pressure drop	1 bar	15 psi
Maximum inlet temperature	32°C	90°F
Maximum outlet temperature	50°C	120°F
Maximum temperature rise	20 K	30°F
Minimum temperature rise	10 K	20°F
Fouling factor on water side	0.35	0.002
	m ² /K/kW	hr-ft ² -°F/Btu
Shell corrosion allowance	3 mm	¼ in

Provision shall be made for complete venting and draining of the system.

Note: The vendor shall notify the purchaser if the criteria for minimum temperature rise and velocity over heat exchange surfaces result in a conflict. The criterion for velocity over heat exchange surfaces is intended to minimize waterside fouling; the criterion for minimum temperature rise is intended to minimize the use of cooling water. The purchaser will approve the final selection.

2.1.5.2 To avoid condensation, the minimum inlet water temperature to the bearing housings should preferably be above the ambient air temperature.

2.1.6 Equipment shall be designed to run without damage to the trip speed and relief valve settings.

2.1.7 The arrangement of the equipment, including piping and auxiliaries, shall be developed jointly by the purchaser and the vendor. The arrangement shall provide adequate clearance areas and safe access for operating and maintenance.

● **2.1.8** Motors, electrical components, and installations shall be suitable for the area classification (class, group, and division or zone) specified by the purchaser and shall meet the requirements of NFPA 70, Articles 500, 501, 502 and 504, as well as local codes specified and furnished by the purchaser.

2.1.9 Oil reservoirs and housings that enclose moving lubricated parts (such as bearings, shaft seals, highly polished parts, instruments, and control elements) shall be designed to minimize contamination by moisture, dust, and other foreign matter during periods of operation and idleness.

2.1.10 All equipment shall be designed to permit rapid and economical maintenance, particularly regarding packing and valves. Major parts shall be designed (shouldered or cylindrically doweled) and manufactured to ensure accurate alignment on reassembly. The machined finish of the mounting surfaces shall be 3–6 micrometers (125–250 microinches) arithmetic average roughness (R_a). Hold-down or foundation bolt holes shall be drilled perpendicular to the mounting surfaces and spot faced to a diameter three times that of the hole.

2.1.11 The machine and its driver shall perform on the test stand and on their permanent foundation within the specified acceptance criteria. After installation, the combined performance of the units shall be the joint responsibility of the purchaser and the vendor having unit responsibility.

● **2.1.12** The installation (indoors, heated or unheated; or outdoors, with or without a roof), the weather and environmental conditions, maximum and minimum temperatures, unusual humidity, and dust or corrosion conditions will be specified.

2.1.13 Spare parts for the machine and all furnished auxiliaries shall meet all the criteria of this standard.

2.2 Selection of Types

2.2.1 A piston pump may be used for differential pressure across the piston less than 138 bar (2000 psi).

2.2.2 A valve plate pump with a removable suction or discharge valve deck and unconfined valve deck gasket may be used for a discharge pressure less than 24 bar gauge (350 psig) and a pumping temperature less 180°C (350°F).

2.3 Ratings

2.3.1 Tables 1 and 2 represent the maximum allowable speed ratings for reciprocating pumps in continuous service. Factors such as viscosity, specific gravity, abrasiveness, vapor pressure, gas solubility or evolution in the pumped liquid, specified pressures and temperatures, or system acceleration head may require further speed limitations.

Table 1—Maximum Allowable Speed Ratings for Power Pumps in Continuous Service

Stroke Length		Single-Acting Plunger-Type Pumps			Double-Acting Piston-Type Pumps		
(mm)	(in)	Revolutions per Minute	Meters per Minute	Feet per Minute	Revolutions per Minute	Meters per Minute	Feet per Minute
50	2	450	45	150	140	14	46.5
75	3	400	60	200	—	—	—
100	4	350	71	233	116	23	77
125	5	310	73	258	—	—	—
150	6	270	82	270	100	30	100
175	7	240	85	280	—	—	—
200	8	210	85	280	—	—	—
250	10	—	—	—	83	42	138
300	12	—	—	—	78	48	156
350	14	—	—	—	74	53	173
400	16	—	—	—	70	57	186

Note: For an intermediate stroke length, the maximum speed shall be interpolated from the numbers in the table.

2.3.2 For installations where NPSHR is within 1.5 meters (5 feet) of the NPSHA (including preliminary estimated system acceleration head), consideration shall be given to speeds lower than those in Tables 1 and 2.

2.3.3 As a guide, for viscosities above 65 square millimeters per second (300 Saybolt Seconds Universal) at pumping temperature, speeds should not exceed a percentage of the speeds given in Tables 1 and 2 as shown on Figure 1.

2.3.4 The liquid end shall be sized using a volumetric efficiency no greater than 95 percent.

● **2.3.5** The volumetric efficiency shall be reduced when necessary to allow for liquid compressibility. The purchaser will supply compressibility data.

2.3.6 In the determination of power-pump power requirements, the pump efficiency shall not be taken as greater than 95 percent. If the power end includes integral speed-reduction gears, the pump efficiency shall not be taken as greater than 92 percent.

Table 2—Maximum Allowable Speed Ratings for Direct-Acting Pumps in Continuous Service

Stroke Length		Speed Rating		
(mm)	(in)	Cycles per Minute	Meters per Minute	Feet per Minute
100	4	52	10.7	35
150	6	44	13.4	44
200	8	38	15.5	51
250	10	34	17.1	56
300	12	30	18.6	61
350	14	28	19.8	65
400	16	26	21.0	69
450	18	24	22.0	72
500	20	22	22.9	75
600	24	20	24.4	80

Note: The power requirement is used for driver sizing.

2.3.7 The power required for driving a single-acting power pump shall be calculated as follows:

$$kW = (Q \times \Delta P) + (Q \times P_d) \left[\left(\frac{1}{Eff} \right) - 1 \right] \left[\frac{1 + P_s}{P_d} \right]$$

In U.S. Customary units, this equates to the following:

$$hp = \frac{(Q \times \Delta P)}{1714} + \frac{(Q \times P_d)}{1714} \left[\left(\frac{1}{Eff} \right) - 1 \right] \left[\frac{1 + P_s}{P_d} \right]$$

Where:

- Q = suction flow, in m³/h (gpm).
- P_d = pump discharge pressure, in bar abs (psia).
- P_s = pump suction pressure, in bar abs (psia).
- Eff = pump overall efficiency, in decimal fraction (2.3.6)
- Δp = P_d - P_s.

2.3.8 The horsepower required for driving a double-acting power pump shall be calculated as follows:

$$kW = \frac{(Q)(P_d - P_s)(100)}{Eff}$$

In U.S. Customary units, this translates to:

$$hp = \frac{(Q)(P_d - P_s)(100)}{(1714)(Eff)}$$

Where:

- Q = section flow, in m³/h (gpm).
- P_d = pump discharge pressure, in bar gauge (psig).
- P_s = pump suction pressure, in bar gauge (psig).
- Eff = pump efficiency, in percent (for above values of P_d and P_s).

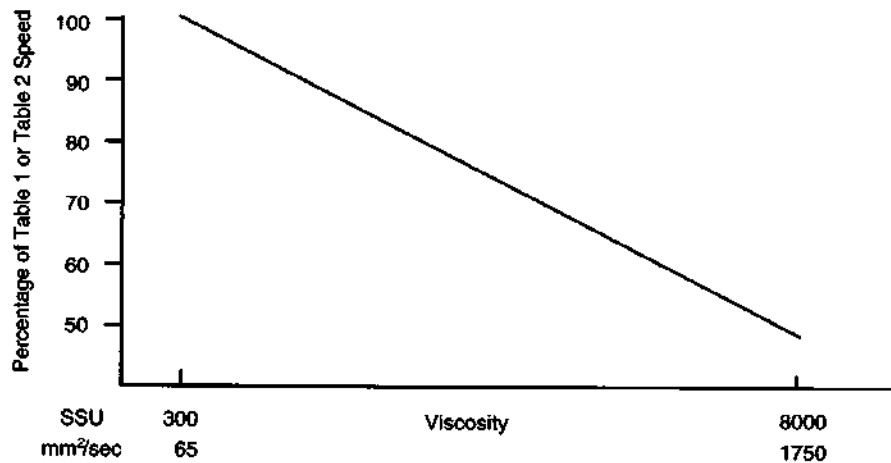

Figure 1—Viscosity Correction to Maximum Allowable Speed Rating

2.3.9 For power pumps, the vendor shall include in the proposal the rated and maximum allowable continuous piston or plunger load. The allowable peak or momentary load, if different from the continuous rating, shall also be specified.

2.3.10 For direct-acting pumps, the vendor shall include in the proposal the liquid stall pressure, calculated as follows:

$$\text{stall pressure} = \left(\frac{\text{gas piston diameter}}{\text{liquid piston diameter}} \right)^2$$

× maximum inlet differential gas pressure

+ maximum liquid suction pressure

2.3.11 A direct-acting pump equipped with a double-acting liquid end piston (as differentiated from a plunger), not equipped with a tail rod of a diameter equal to that of the piston rod, is capable of creating a very high pressure. This pressure, called *ram pressure*, shall be stated in the proposal and shall be calculated as follows:

$$\text{ram pressure} = \left(\frac{\text{gas piston diameter}}{\text{liquid rod diameter}} \right)^2$$

× maximum inlet gas pressure

Note: If the stall pressure or ram pressure exceeds the design pressure of the pump or of any discharge system component, a properly sized relief valve, supplied by the purchaser, is required in the discharge line.

Note: The formulas in 2.3.10 and 2.3.11 are based on 100 percent efficiency during stall or ram conditions.

2.4 Cylinders and Pressure-Retaining Parts (Including Pulsation Suppression Devices)

2.4.1 The hoop-stress values used in the design of the cylinders and pressure-retaining parts shall not exceed the maximum allowable stress values in tension specified in Section VIII, Division 1, of the ASME Code at the maximum operating temperature of the material used.

2.4.2 The maximum allowable working pressure of the cylinder shall be at least equal to the specified relief valve setting; if a relief valve is not specified, the maximum allowable working pressure shall be at least 1.25 times the maximum specified discharge pressure (gauge). System pressure protection will be furnished by the purchaser.

2.4.3 Cylinders, pressure-retaining parts, and supports shall be designed to prevent injurious distortion caused by temperature, pressure, torque, and allowable external forces and moments. Supports and alignment bolts shall be rigid enough to permit the machine to be moved by the use of its lateral and axial jackscrews.

2.4.4 The use of tapped holes in pressure parts shall be minimized. To prevent leakage in pressure sections of casings, metal equal in thickness to at least half of the nominal bolt diameter, in addition to the allowance for corrosion, shall be left around and below the bottom of drilled and tapped holes. The depth of the tapped holes shall be at least one and one-half times the stud diameter.

2.4.5 Bolting shall be furnished as specified in 2.4.5.1 through 2.4.5.5.

2.4.5.1 The details of threading shall conform to ASME B1.1.

2.4.5.2 Studs shall be supplied unless cap screws are specifically approved by the purchaser.

2.4.5.3 Adequate clearance shall be provided at bolting locations to permit the use of socket or box wrenches.

2.4.5.4 Internal socket-type, slotted-nut-type, or spanner-type bolting shall not be used unless specifically approved by the purchaser.

2.4.5.5 Stud ASTM grade markings shall be located on the nut end of the exposed stud end.

2.4.6 Jackscrews, lifting lugs, eyebolts, guide dowels, and alignment dowels shall be provided to facilitate disassembly and reassembly when required by pump design. When jackscrews are used as a means of parting contacting faces, one of the faces shall be relieved (counterbored or recessed) to prevent a leaking joint or improper fit caused by marring. Guide rods shall be of sufficient length to prevent damage to the internals or studs by any component during disassembly and reassembly. Lifting lugs or eyebolts shall be provided for lifting only the top half of the casing.

2.4.7 The cylinder cooling system shall be designed to positively prevent process fluid from leaking into the coolant. When cooling of cylinders is necessary, separate, noninterconnecting jackets are required for cylinder bodies and cylinder heads.

2.5 Cylinder Connections

- **2.5.1** Inlet and outlet connections shall be flanged or machined and studded, oriented as specified, and suitable for the working pressure to which it is normally subjected as defined in 1.4.7.

2.5.2 Connections welded to the cylinder shall meet the material requirements of the cylinder, including impact values, rather than the requirements of the connected piping (2.10.4.5). All welding of connections shall be done before hydrostatic testing (4.3.2).

2.5.3 Cylinder openings for piping connections shall be at least size NPS $\frac{1}{2}$ and shall be flanged or machined and studded. Where flanged or machined and studded openings are impractical, threaded openings in sizes NPS $\frac{1}{2}$ through 1 $\frac{1}{2}$ are permissible. These threaded openings shall be installed as specified in 2.5.3.1 through 2.5.3.7.

2.5.3.1 A pipe nipple, preferably not more than 150 mm (6 inches) long, shall be screwed into the threaded opening.

2.5.3.2 Pipe nipples shall be a minimum of Schedule 160 seamless for sizes NPS 1 and smaller, and a minimum of Schedule 80 for a size of NPS 1 $\frac{1}{2}$.

2.5.3.3 The pipe nipple shall be provided with a welding-neck or socketweld flange.

2.5.3.4 The nipple and flange materials shall meet the requirements of 2.5.2.

2.5.3.5 The threaded connection shall be seal welded; however, seal welding is not permitted on cast iron equipment, for instrument connections, or where disassembly is required for maintenance. Seal-welded joints shall be in accordance with ASME B31.3.

2.5.3.6 Tapped openings and bosses for pipe threads shall conform to ASME B16.5.

2.5.3.7 Pipe threads shall be taper threads conforming to ASME B1.20.1.

2.5.4 Openings for NPS 1 $\frac{1}{4}$, 2 $\frac{1}{2}$, 3 $\frac{1}{2}$, 5, 7, and 9 shall not be used.

2.5.5 Tapped openings not connected to piping shall be plugged with solid round-head steel plugs furnished in accordance with ASME B16.11. As a minimum, these plugs shall meet the material requirements of the cylinder. Plugs that may later require removal shall be of corrosion-resistant material. Lubricant of the proper temperature specification shall be used on all threaded connections. Tape shall not be applied to threads of plugs inserted into oil passages. Plastic plugs are not permitted.

2.5.6 Flanges shall conform to ASME B16.1, B16.5, or B16.42 as applicable, except as specified in 2.5.6.1 through 2.5.6.4.

2.5.6.1 Cast iron flanges shall be flat faced and shall have a minimum thickness of Class 250 per ASME B16.1 for sizes 8 inches and smaller.

2.5.6.2 Flat-faced flanges with full raised-face thickness are acceptable on cases other than cast iron, with purchaser's approval.

2.5.6.3 Flanges that are thicker or have a larger outside diameter than that required by ASME B16.5 or B16.47 are acceptable.

- **2.5.6.4** Connections other than those covered by ASME B16.5 or B16.47 require the purchaser's approval. When specified, the mating parts shall be furnished by the vendor.

2.5.7 Machined and studded connections shall conform to the facing and drilling requirements of ASME B16.1, B16.5, or B16.42. Studs and nuts shall be furnished installed. The first one and one-half threads at both ends of each stud shall be removed. Connections larger than those covered by ASME shall meet the requirements of 2.5.6.4.

2.5.8 All of the purchaser's connections shall be accessible for disassembly without the machine being moved.

2.5.9 No tapped or flanged openings (other than suction or discharge nozzles) shall be furnished in the pumping chambers of the liquid end or in other highly stressed areas subject to cyclic loading unless they are essential for pump operation or performance monitoring.

2.5.10 All flanged openings not to be used for normal operation shall be furnished with blind flanges suitable for the specified service conditions.

2.6 Liquid End Appurtenances

2.6.1 LINERS

Unless otherwise specified, piston-type liquid end cylinders shall be provided with liners as described in 2.6.1.1 through 2.6.1.4.

2.6.1.1 For piston diameters of 100 mm (4 inches) or less, the liner may be pressed into the cylinder.

2.6.1.2 For piston diameters larger than 100 mm (4 inches), the liner shall be flanged and bolted to the cylinder, held in place by jack bolts, and clamped or held in place by followers and set screws.

2.6.1.3 Nonpressed liners shall seal against the cylinder with a gasket or O ring.

2.6.1.4 Liner inside diameter shall be finished to 16 R_a or better.

2.6.2 PISTONS, PLUNGERS, AND PISTON RODS

2.6.2.1 Surfaces of rods or plungers in contact with packing shall be hardened or coated and shall have a minimum hardness of Rockwell C35. Surface finish shall be 16 R_a or better. When endless-ring packing must be installed over the cross-head end of the rod or plunger, the design shall ensure that packing lips will not catch on threads or shoulder.

2.6.2.2 Piston rods, both liquid and drive end, shall be of corrosion-resistant material. For direct-acting pumps, drive end rods and valve rods shall also be of corrosion-resistant material.

2.6.2.3 Pistons or plungers shall be secured to the rods or crossheads with nuts locked with cotter pins or with other fastening and locking methods suitable for the specified service conditions.

2.6.2.4 All compartments of hollow pistons or plungers shall be positively vented.

2.6.2.5 The liquid end of a direct-acting piston pump intended to operate with high-suction pressure shall be equipped with tail rod(s) if the piston-rod load without the tail rod(s) when stroking toward the liquid end exceeds two and one-half times the rod load when stroking toward the gas end, or if the piston rod would be in compression during both strokes.

2.6.3 VALVE SEATS

Valve seats shall be replaceable. For noncorrosive service, seats may be taper threaded into the cylinder. For specified corrosive service, seats shall be taper-press fitted into the valve seat adaptor or cylinder or shall be clamped in place.

2.6.4 GASKETS

Cylinder and valve gaskets shall be of one piece and confined for design pressures over 24 bar gauge (350 psig) or temperatures over 177°C (350°F).

2.6.5 COOLING AND HEATING

If the liquid end requires cooling or heating, such systems shall include provisions for complete venting and draining.

2.6.6 STUFFING BOXES, PACKING, AND GLANDS

2.6.6.1 Unless otherwise specified, liquid end stuffing boxes shall be provided with cooling jackets when handling process liquids above 150°C (300°F) or water above 120°C (250°F). Cooling jackets shall be designed for 5 bar gauge (75 psig) working pressure and 8 bar gauge (115 psig) test pressure.

2.6.6.2 Glands shall bolt to the stuffing box unless otherwise approved by the purchaser. Gland studs shall pass through holes (not slots) in the gland. Headed gland bolts in slots are not acceptable. Axially split glands shall be bolted together. If threaded glands are approved by the purchaser, they shall be provided with gland pawls or equivalent devices to ensure positive locking.

● **2.6.6.3** When specified, glands shall be of the quench type.

2.6.6.4 Liquid end stuffing boxes shall accept a minimum of two square packing rings or two V packing rings (plus adapters) and necessary bushings. If rated suction pressure is below atmospheric, a lantern ring shall be furnished to permit injection of a sealing liquid. If the pumpage contains solids that would shorten the life of the packing or rod (or plunger), an injection lantern ring shall be provided near the box throat. Unless sufficient lubrication is provided by the pumpage, the packing shall be lubricated by liquid that is fed into the stuffing box on the atmospheric side of the packing or by liquid injected into a lantern ring in the stuffing box.

2.6.6.5 The liquid end stuffing box bore finish shall be 63 R_a or better.

2.6.6.6 Liquid end stuffing box primary packing of square or V-ring construction shall be a minimum of 8 mm (3/8 inch) cross section for plunger diameters 25 mm (1 inch) and larger and 6 mm (1/4 inch) for plungers less than 25 mm (1 inch) diameter. Auxiliary packing, if used, shall be a minimum of 6 mm (1/4 inch) cross section.

2.6.6.7 Unless pump construction provides for alternate means of removal, all stuffing box bushings shall be drilled and tapped at two points to facilitate removal with threaded rods.

● **2.6.6.8** For toxic or flammable fluids, or when specified for other fluids, provide a liquid-tight, non-pressurized

collection chamber, with minimum NPS ½ drain and vent connections, to contain packing leakage. When specified, provide a minimum NPS ½ purge connection to direct purge fluid to a lantern ring positioned to minimize pumped fluid leakage to the atmosphere.

Note: It is recognized that this purge fluid may result in increased leakage to the atmosphere. The purchaser and the vendor should review any potential leakage collection/containment system to ensure that all applicable environmental, health, and safety regulations are met.

2.7 Power End Running Gear

- 2.7.1 When specified, the provisions of 2.7.1.1 through 2.7.1.4 shall apply.

2.7.1.1 Crankshafts shall be wrought or cast in one piece.

2.7.1.2 Forced-lubrication passages in crankshafts shall be drilled instead of corèd.

2.7.1.3 Quintuplex pumps shall have a minimum of three main bearings.

2.7.1.4 Septuplex pumps and larger shall have a minimum of four main bearings.

2.7.2 If antifriction bearings are used, they shall have a minimum L-10 rated life (see AFBMA Standard 9) of either 25,000 hours with continuous operation at rated conditions or 16,000 hours at maximum axial and radial loads and rated speed.

Note: The rated life is the number of hours at rated bearing load and speed that 90 percent of the group of identical bearings will complete or exceed before the first evidence of failure.

2.7.2.1 Antifriction bearings shall be retained on the shaft and fitted into housings in accordance with the requirements of AFBMA Standard 7; however, the device used to lock ball thrust bearings to the shaft shall be restricted by a nut with a tongue-type lock washer, for example, Series W.

2.7.2.2 Except for the angular contact type, antifriction bearings shall have a loose internal clearance fit equivalent to AFBMA Symbol 3, as defined in AFBMA Standard 20. Tapered roller bearings shall have a clearance fit as described in AFBMA 11. Single- or double-row bearings shall be of the Conrad type (no filling slots).

2.7.3 Crossheads on power pumps loaded in excess of 525 kW (700 hp) per cylinder shall have replaceable or adjustable shoes or guides. Crosshead bores for pumps loaded in excess of 75 kW (100 hp) per cylinder shall have renewable liners.

2.7.4 The pump design shall ensure adequate lubrication of the crosshead pin bearings for all specified operating conditions, including high-suction-pressure applications.

2.7.5 Internal or bolted-on main gearing shall be either helical or herringbone type and shall be manufactured to the tolerances specified for AGMA Quality Number 8 or better. Gear ratings and service factors shall be in accordance with

AGMA 6010, based on the driver nameplate rating including any driver service factor. Gear and pinion hardness combinations shall be in accordance with the recommended values in AGMA 6010. Hardness combinations of 275 and 320 Brinell or more are preferred for gears and pinions, respectively. The calculated values of gear rated horsepower, based on both tooth surface durability and tooth bending strength, shall be included in the vendor's proposal. If the vendor's standard hardness combination is less than that given above, he shall quote an extra charge to provide that minimum hardness combination.

2.7.6 The frame shall be a cast or fabricated enclosure that will house the crankshaft, connecting rods, crossheads, and bearings, and internal gearing when provided.

2.7.7 Sealing shall be provided at all openings in the frame to prevent contamination of the power end lubricant. All covers shall be gasketed and shall be sufficiently rigid to compress gaskets properly with the bolting supplied.

2.7.8 Gearing in the power end shall use the same oil and sump as the crankshaft and connecting-rod bearings.

- 2.7.9 The power end shall be provided with a filtered vent and a NPS ¼ (minimum) connection for purging. An accessible drain (NPS ½ minimum) shall be provided at the lowest point of the sump. When specified, a drilled, tapped, and plugged connection shall be provided for insertion of an oil heater.

Note: Emissions control methods may require that the power end be pressurized to a slightly higher pressure than that in the distance piece.

2.7.10 The distance piece shall have access openings of adequate size to permit removal of the packing, stuffing box, and parts associated with the stuffing box.

- 2.7.11 The distance piece shall be equipped with safety guards, louvered weather covers, or gasketed solid covers, as specified. Access openings for solid covers shall be surfaced and drilled.

2.7.12 When provided with a solid cover, the distance piece shall be vented (NPS 1 minimum).

2.7.13 Each distance-piece compartment shall be provided with a drain connection (NPS ½ minimum).

2.7.14 Vertical pumps that have the liquid end attached directly to the power end shall have a thermal-barrier distance piece placed between the two ends if the pumped liquid temperature will be above 120°C (250°F) or, depending on conditions, to prevent condensation in the power end.

2.8 Gas End, Direct-Acting Pump

2.8.1 The gas end shall be designed to cushion the piston at the end of of the stroke.

Note: This is to provide uniform deceleration and to prevent contact between reciprocating and stationary components.

2.8.2 The gas cylinder shall be provided either with a liner or with at least 3 mm (1/8 inch) of extra radial thickness for boring to a larger diameter.

2.8.3 D-type slides valves with flat seating surfaces may be supplied for operation with steam temperatures through 260°C (500°F) and steam pressures through 21 bar gauge (300 psig) if the cylinder will operate with lubricant injection into the steam. Seating surfaces shall be resurfaceable by lapping valve and seat.

2.8.4 If the steam temperature is above 260°C (500°F) or if the steam pressure is above 21 bar gauge (300 psig), the main steam valves shall be the radially balanced piston type with removable liners in the steam chest.

2.8.5 The gas piston shall be secured to the rod with a nut. The nut shall be locked to the rod with a cotter pin or with another locking device suitable for the service.

2.8.6 Stuffing boxes, packing, and glands for air and steam shall comply with 2.8.6.1 through 2.8.6.5.

2.8.6.1 Piston-rod stuffing-box bore finish shall be 63 R_a or smoother.

2.8.6.2 The piston-rod stuffing box shall be designed per 2.6.6.4. Packing shall be of square or V-ring construction with a minimum of 8 mm (3/8 inch) cross section.

2.8.6.3 The valve-rod stuffing box shall accept a minimum of three square packing rings or three V packing rings (with adapters) of a minimum size of 5 mm (3/8 inch) square.

2.8.6.4 Packing requiring lubrication shall be lubricated by oil entrained in gas, by oil fed into the stuffing box on the atmospheric side of the packing, or by oil injected into a lantern ring in the stuffing box.

2.8.6.5 Glands shall bolt or thread to the stuffing box. Gland studs shall pass through holes (not slots) in the gland. Axially-split glands shall be bolted together. Headed gland bolts in slots are not acceptable.

2.8.7 The gas end may be of the nonlubricated design if the drive medium is wet steam at 220°C (425°F) or lower. Nonlubricated construction shall include a piston-type main valve, special piston rings, a honed cylinder bore, suitable rod packing, and any other features required for nonlubricated operation.

2.9 Lubrication

2.9.1 LUBRICATION, POWER PUMPS

2.9.1.1 Unless otherwise specified, bearings and bearing housings shall be arranged for hydrocarbon oil lubrication.

- **2.9.1.2** The power end lubrication system may be splash, positive pressure, or gravity as recommended by the pump vendor, or as specified. A sight glass, gauge, or oil-level dipstick shall be provided.

2.9.1.3 All pressure-containing parts in the oil system external to the pump shall be steel unless otherwise approved by the purchaser.

2.9.1.4 The power end oil pump for a pressure system shall be positive displacement, either crankshaft driven or driven by a separate motor.

2.9.1.5 A power end pressure lubrication system shall incorporate an absolute 25 micron or finer filter when oils with a viscosity of less than 330 centistokes (1500 SSU) at 40°C (100°F) are used. With higher viscosity oils, vendor and purchaser shall mutually select a filtration level. The filter shall be easily accessible for servicing.

2.9.1.6 A power end pressure lubrication system shall include a low-oil pressure switch.

- **2.9.1.7** The following auxiliary equipment shall be furnished when required by the vendor or when specified: (1) oil flow indicator, (2) oil pressure gauge (downstream of filter and cooler), (3) oil temperature gauge (downstream of cooler), (4) oil strainer, (5) oil cooler, (6) auxiliary oil pump and driver, and (7) additional instrumentation, alarms, switches, and so forth.

- **2.9.1.8** Unless otherwise specified, bearing oil temperature shall not exceed 70°C (160°F) anywhere in the system. When necessary or when specified, an oil cooler shall be supplied. Any oil cooler provided shall maintain the oil supply temperature at the required temperature. The cooler shall be of a water-cooled, shell-and-tube type or of a suitable air-cooled type, as specified. Shell-and-tube coolers shall have water on the tube side. A removable-bundle design is required for coolers with more than 0.45 square meters (5 square feet) of surface, unless otherwise specified. Removable-bundle coolers shall be in accordance with TEMA Class C and shall be constructed with a removable channel cover. Tubes shall have an outside diameter of at least 15 mm (5/8 inch), and the tube wall thickness shall not be less than 18 BWG [1.25 mm (0.049 inch)]. Unless otherwise specified, cooler shells, channels, and covers shall be of steel; tube sheets shall be of brass; and tubes shall be of inhibited admiralty. U-bend tubes are not permitted. Each cooler shall be sized to accommodate the total cooling load. To prevent the oil from being contaminated if the cooler fails, the oil-side operating pressure shall be higher than the water-side operating pressure. Coolers shall be equipped with vent and drain connections on their oil and water sides. The vendor shall include in the proposal complete details of any proposed air-cooled cooler. Internal oil coolers are not acceptable.

Note: The purchaser should consider the site temperature requirement for personnel protection when evaluating pump oil temperature.

- **2.9.1.9** Full-flow filters with replaceable elements and filtration of 25 microns nominal or finer shall be supplied for

babbitted bearings. Full-flow filters with replaceable elements and filtration of 10 microns nominal or finer shall be supplied for aluminum or microbabbitted bearings. The filters shall be located downstream of the cooler. For turbine-driven centrifugal oil pumps, filter cases and heads shall be suitable for operation at the maximum discharge pressure at the driver's trip speed. For positive displacement pumps, filter cases and heads shall be suitable for operation at a pressure not less than the relief valve setting. Filters that have covers weighing more than 15 kg (35 pounds) shall have cover lifters. Filters shall not be equipped with a relief valve or an automatic bypass. Filter cartridge materials shall be corrosion-resistant. Metal-mesh or sintered-metal filter elements are not acceptable. Flow shall be from the outside toward the center of the filter cartridge. When the filter design requires cartridges stacked two or more high, a center post and a cap for the top cartridge shall be used to secure the cartridges to the bottom of the filter housing. If the cartridge-to-cartridge joint is not self-aligning, a collar shall be used between the stacked cartridges to ensure alignment. The pressure drop for clean filter elements shall not exceed 15 percent of the total allowable dirty pressure drop, or 0.30 bar (5 psi) at the vendor's required operating temperature and normal flow. Cartridges shall have a minimum collapsing differential pressure of 5 bar (70 psi). The filter shall be equipped with a valved vent and clean- and dirty-side valved drain connections. The dirty-side connections shall be located lower in the housing than the filter element or cartridge support base. Where a specific filter element is desired, the purchaser will specify the make and model number of the element.

Note: Micron particle size implies the shape of a spherical bead; thus, a 10-micron particle is a sphere with a diameter of 10 microns. Within the element's recommended maximum pressure drop, 10 microns nominal implies that the efficiency of the filter on particles that are 10 microns or larger in diameter will be no less than 90 percent for the life of the element. Absolute micron particle ratings are different. A micron-absolute filter rating implies that no particles of the rating size or larger will pass; for example, a filter rating may be 10 microns nominal and 15 microns absolute.

- **2.9.1.10** When specified, a removable steam-heating element external to the oil reservoir or a thermostatically controlled electric immersion heater with a sheath of AISI¹² Standard Type 300 stainless steel shall be provided for heating the charge capacity of oil before startup in cold weather. The heating device shall have sufficient capacity to heat the oil in the reservoir from the specified minimum site ambient temperature to the manufacturer's required startup temperature within 12 hours. If an electric immersion heater is used, it shall have a maximum watt density of 2.0 watts per square centimeter (15 watts per square inch).

2.9.1.11 An oil reservoir shall be supplied having the following characteristics and appendages:

¹²American Iron and Steel Institute, 1000 16th Street, NW, Washington, D.C. 20036

- a. The capacity to avoid frequent refilling, to provide adequate allowance for system rundown, and to provide a retention time of at least three minutes to settle moisture and foreign matter adequately.
- b. Provisions to eliminate air and to minimize flotation of foreign matter to the pump suction.
- c. Fill connections, an armored gauge glass, a level indicator, and breathers suitable for outdoor use.
- d. Sloped bottoms and connections for complete drainage.
- e. Cleanout openings as large as practical.

2.9.1.12 When an external oil reservoir is specified, it shall be austenitic stainless steel.

2.9.2 LUBRICATION, LIQUID END, AND GAS END

- **2.9.2.1** When specified, a mechanical lubricator shall be furnished for stuffing box lubrication and any other points requiring lubrication.

2.9.2.2 All lubricator feeds shall be rated for the highest pressure into which the lubricator must pump. For injection into a liquid-end stuffing box lantern ring with packing on both sides, each lubricator feed shall be rated at least equal to pump maximum allowable working pressure.

2.9.2.3 The lubricator shall be furnished with a separate compartment for each type of lubricant required. Each lubricant compartment shall be sized for at least 24 hours of operation at the maximum expected pumping rate.

2.9.2.4 A separate feed shall be furnished for each point of lubrication, unless a divider block is furnished to meter lubricant positively to each point.

2.9.2.5 Unless otherwise specified, the lubricator shall be mounted on the pump. On power pumps, the lubricator may be mechanically driven from the power-frame driving mechanism or may be separately driven. On direct-acting pumps, the lubricator shall be ratchet driven by the pump.

2.9.2.6 A lubricant line designed to withstand the highest pressure that the lubricator will develop shall be supplied and installed for each point of lubrication. For lubrication points that are under pressure, a suitable check valve shall be supplied in the lubricant line, near the point of lubrication.

2.9.2.7 For direct-acting pumps, when the point of lubricant entry for the gas end is in a line supplied by the purchaser, the pump vendor shall furnish the lubricant line and check valve for field installation.

2.10 Materials

2.10.1 GENERAL

2.10.1.1 Materials of construction shall be manufacturer's standard for the specified operating conditions, except as required or prohibited by the data sheets or this standard.

(See 3.5 for auxiliary piping material requirements.) The metallurgy of all major components shall be clearly stated in the vendor's proposal.

2.10.1.2 Materials shall be identified in the proposal with the applicable ASTM, AISI, ASME, or SAE¹³ numbers, including material grade (see Appendix B). When no such designation is available, the vendor's material specification, giving physical properties, chemical composition, and test requirements, shall be included in the proposal.

2.10.1.3 The vendor shall specify the ASTM optional tests and inspection procedures that may be necessary to ensure that materials are satisfactory for the service. Such tests and inspections shall be listed in the proposal. The purchaser may consider specifying additional tests and inspections, especially for materials used in critical components.

2.10.1.4 External parts subject to rotary or sliding motions (such as control linkage joints and adjusting mechanisms) shall be of corrosion-resistant materials suitable for the site environment.

2.10.1.5 Minor parts that are not identified (such as nuts, springs, washers, gaskets, and keys) shall have corrosion-resistance at least equal to that of specified parts in the same environment.

- **2.10.1.6** The purchaser will specify any corrosive agents in the motive and process fluid and in the environment, including constituents that may cause stress corrosion cracking.

2.10.1.7 If parts exposed to conditions that promote intergranular corrosion are to be fabricated, hard faced, overlaid, or repaired by welding, they shall be made of low-carbon or stabilized grades of austenitic stainless steel.

Note: Overlays or hard surfaces that contain more than 0.10 percent carbon can sensitize both low-carbon and stabilized grades of austenitic stainless steel unless a buffer layer that is not sensitive to intergranular attack is applied.

2.10.1.8 Where mating parts such as studs and nuts of AISI Standard Type 300 stainless steel or materials with similar galling tendencies are used, they shall be lubricated with an antiseizure compound of the proper temperature specification and compatible with the specified fluid.

Note: It is preferable to use materials which do not have galling tendencies. Also, torque loading values will be considerably different with and without antiseizure compound.

- **2.10.1.9** Materials exposed to a sour environment (wet H₂S) as defined by NACE MR-01-90 shall be in accordance with the requirements of that standard. Ferrous materials not covered by NACE MR-01-90 shall be limited to a yield strength not exceeding 6200 bar (90,000 pounds per square inch) and a hardness not exceeding Rockwell C 22.

¹³Society of Automotive Engineers, 400 Commonwealth Drive, Warrendale, Pennsylvania 15096

Note: It is the responsibility of the purchaser to determine the amount of H₂S that may be present considering normal operation, startup, shutdown, idle standby, upsets, or unusual operating conditions such as catalyst regeneration. In many applications, small amounts of H₂S are sufficient to require NACE materials. When trace quantities of H₂S are known to be present or if there is any uncertainty about the amount of H₂S present, the purchaser should automatically note that NACE materials are required.

Components that are fabricated by welding shall be stress relieved, if required, so that both the welds and the heat-affected zones meet the yield strength and hardness requirements. The purchaser will specify the presence of such agents in the media.

2.10.1.10 When dissimilar materials with significantly different electrical potentials are placed in contact with the presence of an electrolytic solution, galvanic couples that can result in serious corrosion of the less noble material may be created. If such conditions exist, the purchaser and the vendor should select materials in accordance with the NACE *Corrosion Engineer's Reference Book*.

2.10.1.11 Materials, casting factors, and the quality of any welding shall be equal to those required by Section VIII, Division 1, of the ASME Code. The manufacturer's data report forms, as specified in the code, are not required.

2.10.1.12 The use of ASTM A 515 steel is prohibited. Low-carbon steels can be notch sensitive and susceptible to brittle fracture at ambient or low temperatures. Therefore, only fully killed, normalized steels made to fine-grain practice are acceptable.

2.10.1.13 The minimum quality bolting material for pressure joints shall be carbon steel (ASTM A 307, Grade B) for cast iron castings and high-temperature alloy steel (ASTM A 193, Grade B7) for steel casings. Nuts shall conform to ASTM A 194, Grade 2H (or ASTM A 307, Grade B, case hardened where space is limited). For temperatures below -30°C (-20°F), low-temperature bolting material in accordance with ASTM A 320 shall be used.

2.10.2 CASTINGS

2.10.2.1 Castings shall be sound and free from hot tears, shrink holes, blow holes, cracks, scale, blisters, and similar injurious defects. Porosity shall not exceed the limits stated in the material inspection acceptance criteria (4.2.2). Surfaces of castings shall be cleaned by sandblasting, shot-blasting, chemical cleaning, or any other standard method. Mold-parting fins and remains of gates and risers shall be chipped, filed, or ground flush.

2.10.2.2 The use of chaplets in pressure castings shall be held to a minimum. The chaplets shall be clean and corrosion free (plating permitted) and of a composition compatible with the casting.

2.10.2.3 Ferrous castings for pressure retaining parts shall not be repaired by welding, peening, plugging, burning in, or impregnating, except as specified in 2.10.2.3.1 and 2.10.2.3.2.

2.10.2.3.1 Weldable grades of steel castings may be repaired by welding, using a qualified welding procedure based on the requirements of Section VIII, Division 1, and Section IX of the ASME Code.

2.10.2.3.2 Cast gray iron or nodular iron may be repaired by plugging within the limits specified in ASTM A 278, A 395, or A 536. The holes drilled for plugs shall be carefully examined, using liquid penetrant, to ensure that all defective material has been removed. All repairs that are not covered by ASTM specifications shall be subject to the purchaser's approval.

2.10.2.4 Fully enclosed cored voids, including voids closed by plugging, are prohibited.

2.10.2.5 Grey cast iron (ASTM A 278) shall not be used for pressure-containing parts that handle flammable or toxic fluids. With the purchaser's recommendation approval, nodular cast iron (ASTM A 395) may be used in such services.

Note: It is recommended that nodular cast iron be used only for services less than 14 bar gauge (200 psig) and 50°C (125°F).

2.10.2.6 Nodular iron castings shall be produced in accordance with ASTM A 395. The production of the castings shall also conform to the conditions specified in 2.10.2.6.1 through 2.10.2.6.5.

2.10.2.6.1 A minimum of one set (three samples) of Charpy V-notch impact specimens at one-third the thickness of the test block shall be made from the material adjacent to the tensile specimen on each keel or Y block. These specimens shall have a minimum impact value of 14 joules (10 foot-pounds) at room temperature.

2.10.2.6.2 The keel or Y block cast at the end of the pour shall be at least as thick as the thickest section of the main casting.

2.10.2.6.3 Integrally cast test bosses, preferably at least 25 mm (1 inch) in height and diameter, shall be provided at critical areas of the casting for subsequent removal for the purposes of hardness testing and microscopic examination. Critical areas are typically heavy sections, section changes, high-stress points such as drilled lubrication points, the cylinder bore, valve ports, flanges, and other points agreed upon by the purchaser and the vendor. Classification of graphite nodules shall be in accordance with ASTM A 247.

2.10.2.6.4 An as-cast sample from each ladle shall be chemically analyzed.

2.10.2.6.5 Brinell hardness readings shall be made on the actual casting at feasible locations on section changes, flanges, the cylinder bore, and valve ports. Sufficient surface material shall be removed before hardness readings are made, to eliminate any skin effect. Readings shall also be made at the extremities of the casting at locations that repre-

sent the sections poured first and last. These shall be made in addition to Brinell readings on the keel or Y blocks.

2.10.3 FORGINGS

Unless otherwise agreed upon by the purchaser and the vendor, the forging material shall be selected from those listed in Appendix B.

2.10.4 WELDING

2.10.4.1 Welding of piping and pressure-containing parts, as well as any dissimilar metal welds and weld repairs, shall be performed and inspected by operators and procedures qualified in accordance with Section VIII, Division 1, and Section IX of the ASME Code. The manufacturers data report forms as specified in the code are not required.

2.10.4.2 The vendor shall be responsible for the review of all repairs and repair welds to ensure that they are properly heat treated and nondestructively examined for soundness and compliance with the applicable qualified procedures (see 2.10.1.11). Repair welds shall be nondestructively tested by the same method used to detect the original flaw. As a minimum, this shall be in accordance with 4.2.2.4 for magnetic materials and liquid penetrant method in accordance with 4.2.2.5 for non-magnetic material.

2.10.4.3 Unless otherwise specified, all welding other than that covered by Section VIII, Division 1, of the ASME Code and ASME B31.3, such as welding on baseplates, nonpressure ducting, lagging, and control panels, shall be performed in accordance with AWS D1.1.

2.10.4.4 Pressure-containing components made of wrought materials or combinations of wrought and cast materials shall conform to the conditions specified in 2.10.4.4.1 through 2.10.4.4.4.

2.10.4.4.1 Plate edges shall be inspected by magnetic particle or liquid penetrant examination as required by Section VIII, Division 1, UG-93(d)(3), of the ASME Code.

2.10.4.4.2 Accessible surfaces of welds shall be inspected by magnetic particle or liquid penetrant examination after backchipping or gouging and again after postweld heat treatment.

2.10.4.4.3 Pressure-containing welds, including welds of the cylinder to horizontal- and vertical-joint flanges, shall be full-penetration welds.

2.10.4.4.4 Fabricated cylinders, except for austenitic stainless steel material, (regardless of thickness) shall be postweld heat treated as required by the appropriate ASTM specification.

2.10.4.5 Connections welded to fluid cylinders shall be installed as specified in 2.10.4.5.1 through 2.10.4.5.5.

- **2.10.4.5.1** In addition to the requirements of 2.10.4.1, the purchaser may specify that 100 percent radiography, magnetic particle inspection, or liquid penetrant inspection of welds is required.

2.10.4.5.2 Auxiliary piping welded to chromium-molybdenum alloy steel or 12 percent chrome steel components shall be of the same material, except that chromium-molybdenum alloy steel pipe may be substituted for 12 percent chrome steel pipe.

2.10.4.5.3 When heat treating is required, piping welds shall be made before the component is heat treated.

- **2.10.4.5.4** When specified, proposed connection designs shall be submitted to the purchaser for approval before fabrication. The drawing shall show weld designs, size, materials, and preweld and postweld heat treatments.

2.10.4.5.5 All welds shall be heat treated in accordance with Section VIII, Division 1, UW-40, of the ASME Code.

● 2.10.5 IMPACT TEST REQUIREMENTS

2.10.5.1 To avoid brittle fracture during operation, maintenance, transportation, erection, and testing, good design practice shall be followed in the selection of fabrication methods, welding procedures, and materials for vendor-furnished steel pressure-retaining parts that may be subject to temperature below the ductile-brittle transition point.

Note: The published design-allowable stresses for many materials in the ASME Code and ANSI Standards are based on minimum tensile properties. The ASME Code and ANSI Standards do not differentiate between rimmed, semikilled, fully killed, hot-rolled and normalized material. Nor do they take into account whether materials were produced under fine- or coarse-grain practices. The vendor shall exercise caution in the selection of materials intended for services between -30°C (-20°F) and 40°C (100°F).

2.10.5.2 All pressure containing components including nozzles, flanges, and weldments shall be impact tested in accordance with the requirements of Section VIII, Division 1, Sections USC-65 through 68, of the ASME Code. High-alloy steels shall be tested in accordance with Section VIII, Division 1, Section UHA-51, of the ASME Code.

Impact testing is not required if the requirements of Section VII, Division 1, Section UG-20F, of the ASME Code are met.

Nominal thickness for castings as defined in Section VIII, Division 1, Paragraph UCS-66(2), of the ASME Code shall exclude structural support sections such as feet or lifting lugs.

The results of the impact testing shall meet the minimum impact energy requirements of Section VIII, Division 1, Section UG-84, of the ASME Code.

2.10.5.3 The purchaser will specify the minimum design metal temperature used to establish impact test requirements.

Note: Normally this will be the lower of the minimum surrounding ambient temperature or minimum fluid pumping temperature; however, the purchaser may specify a minimum metal temperature based on fluid pumped properties such as autorefrigeration at reduced pressures.

2.11 Nameplates and Rotation Arrows

2.11.1 A nameplate shall be securely attached at a readily visible location on the equipment and on any other major piece of auxiliary equipment.

2.11.2 Rotation arrows shall be cast in or attached to each major item of rotating equipment in a readily visible location. Nameplates and rotation arrows (if attached) shall be of ANSI Standard Type 300 stainless steel or of nickel-copper alloy (Monel or its equivalent). Attachment pins shall be of the same material. Welding is not permitted.

- **2.11.3** The purchaser's item number, the vendor's name, the machine's serial number, and the machine's size and type, as well as its minimum and maximum allowable design limits and rating data (including pressures, temperatures, speeds, and power), maximum allowable working pressures and temperatures, and hydrostatic test pressure, shall appear on the machine's nameplate. The purchaser will specify whether U.S. Customary or SI units are to be shown.

2.11.4 Power pumps shall be provided with an instruction plate mounted in a conspicuous place on the power frame. The instruction plate shall specify the type and quantity of lubricant required for the power end.

2.12 Quality

Refer to API RP 683 for guidelines on improving the quality of equipment.

SECTION 3—ACCESSORIES

3.1 Drivers

- **3.1.1** The type of driver will be specified. The driver shall be sized to meet the maximum specified operating conditions, including external gear and/or coupling losses, and shall be in accordance with applicable specifications, as stated in the inquiry and order. The driver shall be suitable for satisfactory operation under the utility and site conditions specified.
- **3.1.2** Anticipated process variations that may affect the sizing of the driver (such as changes in the pressure, temperature, or properties of the fluid handled, as well as special plant startup conditions) will be specified.
- **3.1.3** The starting conditions for the driven equipment will be specified, and the starting method shall be mutually agreed upon by the purchaser and the vendor. The driver's starting-torque capabilities shall exceed the starting-torque requirements of the driven equipment.

3.1.4 For motor-driven units, the motor nameplate rating (exclusive of the service factor) shall be at least 110 percent of the maximum power required for any of the specified operating conditions. The motor nameplate rating including service factor shall be suitable for operation at 110 percent of the relief valve setting. Equipment driven by induction motors shall be rated at the actual motor speed for the rated load calculation.
- **3.1.5** The purchaser will specify the type of motor and its characteristics and accessories, including the following:
 - a. Electrical characteristics.
 - b. Starting conditions (including the expected voltage drop on starting).
 - c. The type of enclosure.
 - d. The sound pressure level.
 - e. The area classification based on API Recommended Practice 500.
 - f. The type of insulation.
 - g. The required service factor.
 - h. The ambient temperature and elevation above sea level.
 - i. Transmission losses.
 - j. Temperature detectors, vibration sensors, and heaters, if these are specified.
 - k. Auxiliaries (such as motor-generator sets, a ventilation blower, and instrumentation).
 - l. Vibration acceptance criteria.
- **3.1.6** The motor's starting-torque requirements shall be met at a specified reduced voltage, and the motor shall accelerate to full speed within a period of time agreed upon by the purchaser and the vendor.

Note: For most applications, the starting voltage is typically 80 percent of the normal voltage, and the time required to accelerate to full speed is generally less than 15 seconds.

3.1.7 Motors for belt or chain drives shall be of extended-shaft construction and shall be suitable for the side loads imposed by the drive.

- **3.1.8** Steam turbine drivers shall conform to API Standard 611 or 612 as specified. Steam turbine drivers shall be sized to continuously deliver 110 percent of the maximum power required for the purchaser's specified conditions while operating at a corresponding speed with the specified steam conditions.
- 3.1.9** Gear units integral with motor drivers are acceptable only if the driver nameplate rating is 18 kW (25 horsepower) or less. These integral gear units shall conform to AGMA 6019, Class III for duplex power pumps, or Class II for multiplex power pumps.
- **3.1.10** Coupled gears shall be either single helical or double helical herringbone type and shall conform to AGMA Standard 6010. When specified, gears shall conform to API Standard 677 or 613.
- 3.1.11** The gear service factor shall be mutually agreed upon by the gear and pump manufacturers, subject to approval by the purchaser, for given service conditions such as variable torque loading, torsional critical speeds, and the like. In no case shall the service factor be less than that required by the latest editions of AGMA 6010 for standard gear reducers and API Standards 613 or 677 where specified.
- **3.1.12** Belt drives shall be limited to pumps of 150 kW (200 brake horsepower) or less and shall be banded multi-vee belts, unless otherwise specified. If more than one banded multi-vee belt is required, the vendor shall furnish matched belt lengths. All belt drives shall be oil resistant (with a Neoprene or equivalent material cover). The drive service factor shall not be less than 1.5 for multiplex plunger pumps, 1.6 for duplex double-acting piston pumps, and 1.75 for duplex single-acting pumps. When service in a hazardous area is specified, belt drivers of the static-conducting type shall be provided (see 3.2 for belt drive guards).
- 3.1.13** The vendor shall provide a positive belt-tensioning device on all belt drives. This device shall incorporate a lateral adjustable base with guides and hold-down bolts, two belt-tensioning screws, and locking bolts.
- 3.1.14** The vendor with unit responsibility shall inform the manufacturer of the connected equipment when a belt drive is to be used. The driver manufacturer shall be provided with the belt drive's radial-load and vibratory-torque characteristics. These characteristics shall be taken into account when the driver is selected.
- 3.1.15** V belt speeds shall not exceed 1500 meters per minute (5000 feet per minute).

- **3.1.16** When specified, a cog-belt or chain-type drive shall be provided. Details shall be mutually agreed upon between the vendor and the purchaser.

3.1.17 For drivers that weigh more than 250 kg (500 pounds), the equipment feet shall be provided with vertical jackscrews.

3.2 Couplings and Guards

3.2.1 Unless otherwise specified, flexible couplings and guards between drivers and driven equipment shall be supplied by the manufacturer of the driven equipment.

- **3.2.2** When specified, couplings, coupling-to-shaft juncture, and guards shall conform to API Standard 671. The make, type, and mounting arrangement of couplings shall be agreed upon by the purchaser and the vendors of the driver and driven equipment.

3.2.3 Couplings shall be selected with a service factor not less than that recommended by the coupling manufacturer for the intended service.

3.2.4 Information on shafts, keyway dimensions (if any), and shaft end movements due to end play and thermal effects shall be furnished to the vendor supplying the coupling.

- **3.2.5** When the driven-equipment vendor is not required to mount the driver, the coupling purchaser shall deliver the fully machined half-coupling to the driver manufacturer's plant or any other designated location, together with the necessary instructions for mounting the half-coupling on the driver shaft as specified.

3.2.6 The purchaser of the coupling shall supply an idling adapter, if required, for the mechanical running test (4.3.3 or 4.3.4).

3.2.7 When the driver is a horizontal sleeve-bearing motor, limited end-float couplings shall be furnished to prevent end contact between shoulders on the motor shaft and its bearings.

3.2.8 Guards shall be provided on any moving parts that could be hazardous to personnel. They shall be supplied by the pump vendor, unless otherwise specified. They shall be removable for purposes of inspection, adjustment, or maintenance of the guarded component(s) and shall be sufficiently rigid to prevent contact with moving parts as a result of bodily contact.

3.2.9 Guards shall be supplied by the vendor for exposed shafts, belts, or couplings. They shall be manufactured in accordance with all specified codes.

3.3 Mounting Plates

3.3.1 GENERAL

- **3.3.1.1** The equipment shall be furnished with soleplates, a baseplate, or skid, as specified.

3.3.1.2 In 3.3.1.2.1 through 3.3.1.2.12, the term *mounting plate* refers to baseplates, soleplates, and skids.

3.3.1.2.1 All machinery mounting surfaces on the mounting plates shall be machined flat and parallel after fabrication and shall extend at least 25 mm (1 inch) beyond the outer three sides of the equipment feet. To prevent a soft foot, all surfaces on which a piece of equipment mounts shall be in the same plane within 50 micrometers (0.002 inches) (see Figure 2). The maximum surface finish shall be 3 micrometers (125 microinches) R_a .

3.3.1.2.2 When the equipment supported weighs more than 250 kg (500 pounds), the mounting plates shall be furnished with axial and lateral jackscrews the same size as or larger than the vertical jackscrews. Vertical jackscrews in the equipment feet shall be arranged to prevent marring of shimming surfaces. The lugs holding these jackscrews shall be attached to the mounting plates so that the lugs do not interfere with the installation or removal of the equipment, jackscrews, or shims. If the equipment is too heavy to use jackscrews, other means shall be provided.

3.3.1.2.3 Machinery supports shall be designed to limit a change of alignment caused by the worst combination of pressure, torque, and allowable piping stress to 50 micrometers (0.002 inch) at the coupling flange.

3.3.1.2.4 When centerline supports are provided, they shall be designed and manufactured to permit the machine to be moved by using the horizontal jackscrews.

3.3.1.2.5 Unless otherwise specified, epoxy grout shall be used. The vendor shall commercially sandblast, in accordance with SSPC SP6, all the grouting surfaces of the mounting plates and shall precoat these surfaces with a catalyzed epoxy primer applied to degreased white metal. The epoxy primer shall be compatible with epoxy grout. The vendor shall submit to the purchaser instructions for field preparation of the epoxy primer.

Note: Epoxy primers have a limited life after application. The grout manufacturer should be consulted to ensure proper field preparation of the mounting plate for satisfactory bonding of the grout.

3.3.1.2.6 Anchor bolts shall not be used to fasten machinery to the mounting plates.

3.3.1.2.7 Mounting plates shall not be drilled for equipment to be mounted by others. Mounting plates shall be supplied with leveling screws. Mounting plates that are to be grouted shall have 50 mm (2 inch) radiused outside corners (in the plan view). Mounting surfaces that are not to be grouted shall be coated with a rust preventative immediately after machining.

3.3.1.2.8 Mounting plates shall be designed to extend at least 25 mm (1 inch) beyond the outer three sides of equipment feet.

3.3.1.2.9 The vendor of the mounting plates shall furnish stainless-steel (AISI Standard Type 300) shim packs of at

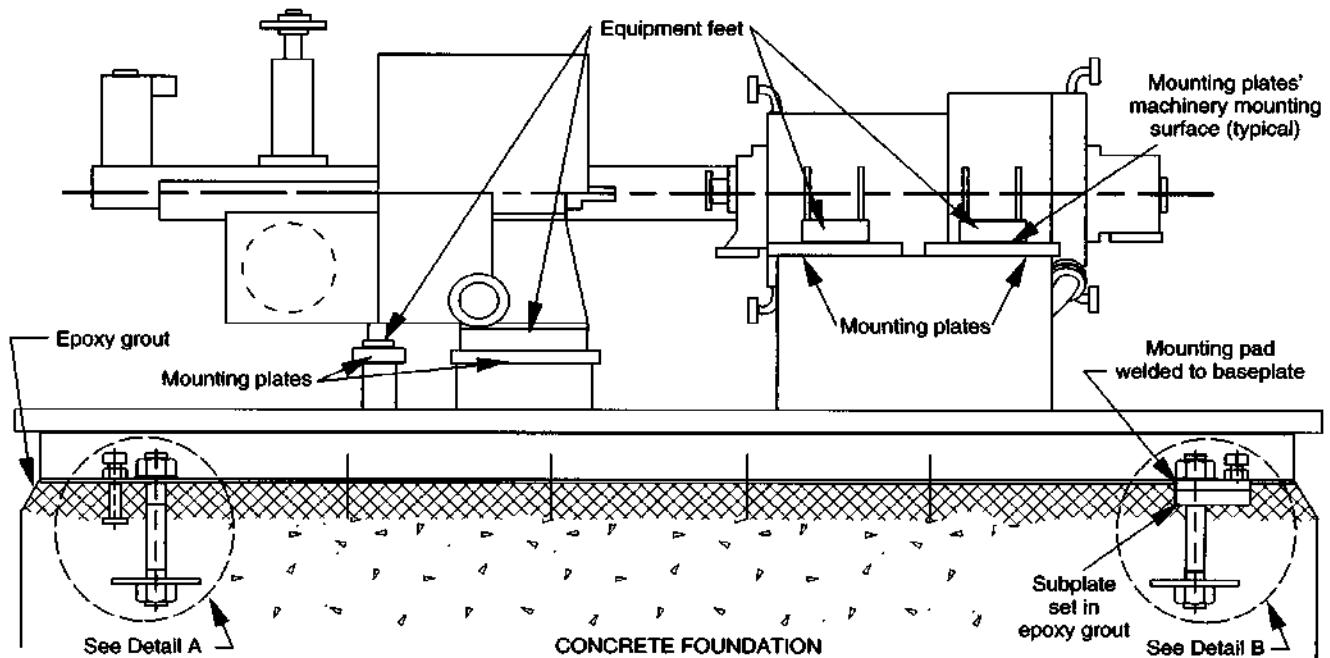

Anchor bolt hole clearance in baseplate 6 mm (1/4 inch) larger than anchor bolt (typical)

Grease leveling screw threads

Leveling block

STANDARD BEDPLATE DESIGN

Detail A

Anchor bolts

Bottom of mounting pad parallel with machinery mounting surface

Baseplate (Bedplate)

Duxseal or foam insulation wrapped around anchor bolt threads

Epoxy grout

Anchor bolt sleeve filled with silicone or polysulfide joint sealant to seal out water and oil

Welded plate/nut or J bolt

ALTERNATE HYDRAULIC JACK

Detail C

Either drilled and tapped or welded nut jacking bolt may be used. Note: See Detail C for alternate hydraulic jack instead of jack bolts for heavy units.

Epoxy grout

Shims

Concrete

OPTIONAL MOUNTING PAD DESIGN

Detail B

Hydraulic jack

Subplate

Figure 2—Baseplate Mounting Pad Arrangement

least 3 mm ($\frac{1}{8}$ inch) total thickness between the equipment feet and the mounting plates. All shim packs shall straddle the hold-down bolts and vertical jackscrews, and shall be at least 5 mm ($\frac{1}{4}$ inch) larger on all sides than the footprint of the equipment.

3.3.1.2.10 Anchor bolts will be furnished by the purchaser.

3.3.1.2.11 Fasteners for attaching the components to the mounting plates and jackscrews for leveling the pedestal soleplates shall be supplied by the vendor.

3.3.1.2.12 The equipment feet shall be drilled with pilot holes that are accessible for use in final doweling.

3.3.2 BASEPLATE AND SKID

- **3.3.2.1** When a baseplate or skid is specified, the purchaser will indicate the major equipment to be mounted on it. A baseplate shall be a single fabricated steel unit, unless the purchaser and the vendor mutually agree that it may be fabricated in multiple sections. Multiple-section baseplates shall have machined and doweled mating surfaces to ensure accurate field reassembly.

Note: A baseplate with a nominal length of more than 12 meters (40 feet) or a nominal width of more than 4 meters (12 feet) may have to be fabricated in multiple sections because of shipping restrictions.

3.3.2.2 Unless otherwise specified, the baseplate or skid shall extend under the drive train components so that any leakage from these components is contained within the baseplate.

- **3.3.2.3** When specified, the baseplate shall be provided with leveling pads or targets protected with removable covers. The pads or targets shall be accessible for field leveling after installation, with the equipment mounted and the baseplate on the foundation.
- **3.3.2.4** When specified, the baseplate shall be suitable for column mounting (that is, of sufficient rigidity to be supported at specified points) without continuous grouting under structural members. The baseplate design shall be mutually agreed upon by the purchaser and the vendor.

3.3.2.5 The baseplate or skid shall be provided with lifting lugs for a four-point lift. Lifting the baseplate or skid complete with all equipment mounted shall not permanently distort or otherwise damage the baseplate or machinery mounted on it.

3.3.2.6 The bottom of the baseplate between structural members shall be open. When the baseplate is installed on a concrete foundation, it shall be provided with at least one grout hole having a clear area of at least 0.01 square meters (20 square inches) and no dimension less than 75 mm (3 inches) in each bulkhead section. These holes shall be located to permit grouting under all load-carrying structural members. Where practical, the holes shall be accessible for

grouting with the equipment installed. The holes shall have 15 mm ($\frac{1}{2}$ inch) raised-lip edges, and if located in an area where liquids could impinge on the exposed grout, metallic covers with a minimum thickness of 16 gauge shall be provided. Vent holes at least 15 mm ($\frac{1}{2}$ inch) in size shall be provided at the highest point in each bulkhead section of the baseplate.

- **3.3.2.7** The mounting pads on the bottom of the baseplate shall be in one plane to permit use of a single-level foundation. When specified, subplates shall be provided by the vendor.

3.3.2.8 Unless otherwise specified, nonskid decking covering all walk and work areas shall be provided on the top of the baseplate.

3.3.2.9 Baseplate mounting pads shall be machined after baseplate fabrication is complete.

3.3.2.10 Baseplates shall be of the drain-rim or drain-pan type and shall have a raised lip. Connections for a drain shall be tapped (NPS 1 minimum) in the raised lip at the pump end and shall be located for complete drainage. The pan or upper surface of the baseplate shall be sloped 1:120 minimum toward the drain end.

3.3.2.11 The underside of fabricated baseplate decking located under the pump and driver supports shall be welded to the cross members.

3.3.2.12 Mounting pads shall be provided for the pump and all drive train components. The pads shall be larger than the foot of the mounted equipment to allow leveling of the baseplate without removal of the equipment. The pads shall be fully machined flat and parallel. Corresponding surfaces shall be in the same plane within 1:6000 of distance between the pads. This requirement shall be met by supporting and clamping the baseplate at the foundation bolt holes only. Provision for shims between such surfaces shall not eliminate this requirement.

3.3.2.13 The requirements listed above for baseplates, except for 3.3.2.6, 3.3.2.7, and 3.3.2.12 shall apply when a skid is specified.

3.4 Controls and Instrumentation

3.4.1 GENERAL

3.4.1.1 Unless otherwise specified, instrumentation and installation shall conform to API Standard 614.

3.4.1.2 Unless otherwise specified, controls and instrumentation shall be suitable for outdoor installation.

3.4.1.3 Where applicable, controls and instrumentation shall conform to API RP 550.

3.4.2 CONTROL SYSTEMS

Note: Capacity control is normally obtained by flow bypass or by variation in pump speed, with or without supplemental bypass.

3.4.2.1 For a variable-speed drive, the control signal shall act to adjust the set point of the driver's speed-control system. Unless otherwise specified, the control and operating speed range shall be from the maximum continuous speed to 95 percent of the minimum speed required for any specified operating case or 70 percent of the maximum continuous speed, whichever is lower.

- **3.4.2.2** When specified, a combination of control modes shall be required on drives with a limited speed range and for multiservice or multistream applications.

3.4.2.3 The full range of the specified control signal will correspond to the required operating range of the driven equipment. Unless otherwise specified, the maximum control signal shall correspond to the maximum continuous speed or the maximum flow.

- **3.4.2.4** When a direct-acting, constant-speed pump governor and governor valve are specified, the system shall be furnished as described in 3.4.2.4.1 and 3.4.2.4.2.

3.4.2.4.1 Unless otherwise specified, speed shall be adjusted by means of a hand-speed changer.

3.4.2.4.2 Actuation of the control signal or failure of the signal or actuator shall neither prevent the governor from limiting the speed to the maximum permissible nor prevent manual regulation with the hand-speed changer.

3.4.2.5 When a governor is not specified, the throttle valve for pump speed control will be furnished by the purchaser.

3.4.3 INSTRUMENT AND CONTROL PANELS

- **3.4.3.1** When specified, a panel shall be provided and shall include all panel-mounted instruments for the driven equipment and the driver. Such panels shall be designed and fabricated in accordance with the purchaser's description. The purchaser will specify whether the panel is to be freestanding, located on the base of the unit, or in another location. The instruments on the panel shall be clearly visible to the operator from the driver control point. A lamp test pushbutton shall be provided. The instruments to be mounted on the panel will be specified.

3.4.3.2 Panels shall be completely assembled, requiring connection only to the purchaser's external piping and wiring circuits. When more than one wiring point is required on a unit for control or instrumentation, the wiring to each switch or instrument shall be provided from a single terminal box with terminal posts mounted on the unit (or its base, if any). Wiring shall be installed in metal conduits or enclosures. All leads and posts on terminal strips, switches, and instruments shall be tagged for identification.

3.4.4 INSTRUMENTATION

- **3.4.4.1 Tachometer**

A tachometer shall be provided for engine-driven units and, when specified, for other variable-speed units. The type

of tachometer will be specified. Unless otherwise specified, the minimum tachometer range shall be from 0 to 125 percent of the maximum continuous speed.

3.4.4.2 Temperature Gauges

3.4.4.2.1 Dial-type temperature gauges shall be heavy-duty and corrosion resistant. They shall be at least 125 mm (5 inches) in diameter and bimetallic type or liquid filled. Black printing on a white background is standard for gauges.

3.4.4.2.2 The sensing elements of thermometers and temperature gauges shall be in the flowing fluid.

Note: This is particularly important for lines that may run partially full.

3.4.4.3 Thermowells

Temperature gauges that are in contact with flammable or toxic fluids or that are located in pressurized or flooded lines shall be furnished with NPS $\frac{1}{2}$ AISI Standard Type 300 stainless steel separable solid-bar thermowells.

3.4.4.4 Thermocouples and Resistance Temperature Detectors

Where practical, the design and location of thermocouples and resistance temperature detectors shall permit replacement while the unit is operating. The lead wires of thermocouples and resistance temperature detectors shall be installed as continuous leads between the thermowell or detector and the terminal box. Conduit runs from thermocouple heads to a pull box or boxes located on the baseplate shall be provided.

- **3.4.4.5 Pressure Gauges**

Pressure gauges (not including built-in instrument air gauges) shall be furnished with AISI Standard Type 316 stainless steel bourdon tubes and stainless steel movements, 110 mm (4½ inch) dials [150 mm (6 inch) dials for the range over 55 bar (800 psi)] and NPS $\frac{1}{2}$ male alloy steel connections. Black printing on a white background is standard for gauges. When specified, liquid-filled gauges shall be furnished in locations subject to vibration. Gauge ranges shall preferably be selected so that the normal operating pressure is at the middle of the gauge's range. In no case, however, shall the maximum reading on the dial be less than the applicable relief valve setting plus 10 percent. Each pressure gauge shall be provided with a device, such as a disk insert or blowout back, designed to relieve excess case pressure.

3.4.4.6 Solenoid Valves

Solenoid-operated valves shall have Class F insulation or better, and shall have a continuous service rating.

3.4.4.7 Relief Valves

3.4.4.7.1 Relief valves or other protective devices shall always be used with power pumps, and with direct-acting

pumps if the stall pressure or the ram pressure exceeds the maximum allowable working pressure.

3.4.4.7.2 The vendor shall furnish the relief valves that are to be installed on equipment or in piping that the vendor is supplying. Other relief valves will be furnished by the purchaser. Relief valves for all operating equipment shall meet the limiting relief valve requirements defined in API Recommended Practice 520, Parts I and II, and in API Standard 526. The vendor shall determine the size, and set the pressure of all relief valves related to the equipment. The vendor's quotation shall list all relief valves and shall clearly indicate those to be furnished by the vendor. Relief valve settings, including accumulation, shall take into consideration all possible types of equipment failure and the protection of piping systems.

3.4.4.7.3 Liquid-end discharge relief valves must be able to handle the pump rated capacity.

3.4.4.7.4 Unless otherwise specified, relief valves shall have steel bodies.

- **3.4.4.7.5** When specified, thermal relief valves shall be provided for components that may be blocked in by isolation valves.

3.4.4.7.6 Relief valves provided for ram pressure must discharge outside of pump block valves. (2.3.11)

● 3.4.4.8 Flow Indicators

When specified, restrictive flow indicators shall be installed in the pressurized inlet line to each continuously lubricated coupling.

3.4.5 ALARMS AND SHUTDOWNS

● 3.4.5.1 General

Switches, control devices, and annunciator display units shall be furnished and mounted by the vendor as specified and may include those listed in Table 3. The alarm setting shall precede the shutdown setting.

● 3.4.5.2 Annunciator

The vendor shall furnish a first-out annunciator when an annunciator system is specified. The annunciator shall contain approximately 25 percent spare points and, when specified, shall be arranged for purging. Connections shall be provided for actuation of a remote signal when any function alarms or trips. The sequence of operation shall be as specified in 3.4.5.2.1 through 3.4.5.2.3.

3.4.5.2.1 Alarm indication shall consist of the flashing of a light and the sounding of an audible device.

3.4.5.2.2 The alarm condition shall be acknowledged by operating an alarm-silencing button common to all alarm functions.

3.4.5.2.3 When the alarm is acknowledged, the audible device shall be silenced, but the light shall remain steadily lit as long as the alarm condition exists. The annunciator shall be capable of indicating a new alarm (with a flashing light and sounding horn) if another function reaches an alarm condition, even if the previous alarm condition has been acknowledged but still exists.

3.4.5.3 Alarm and Trip Switches

3.4.5.3.1 Each alarm switch and each shutdown switch shall be furnished in a separate housing located to facilitate inspection and maintenance. Hermetically sealed, single-pole, double-throw switches with a minimum capacity of 5 amperes at 120 volts AC and ½ ampere at 120 volts DC shall be used. Mercury switches shall not be used.

3.4.5.3.2 Unless otherwise specified, electric switches that open (de-energize) to alarm and close (energize) to trip shall be furnished by the vendor.

3.4.5.3.3 Alarm and trip switch settings shall not be adjustable from outside the housing. Alarm and trip switches shall be arranged to permit testing of the control circuit, including, when possible, the actuating element, without interfering with normal operation of the equipment. The vendor shall provide a clearly visible light on the panel to indicate when trip circuits are in a test bypass mode. Unless otherwise specified, shutdown systems shall be provided with switches or another suitable means to permit testing without shutting down the unit.

3.4.5.3.4 Pressure-sensing elements shall be of AISI Standard Type 300 stainless steel. Low-pressure alarms, which are activated by falling pressure, shall be equipped with a valved bleed or vent connection to allow controlled depressurizing so that the operator can note the alarm set pressure on the associated pressure gauge. High-pressure alarms, which are activated by rising pressure, shall be

Table 3—Conditions Requiring Alarms and Shutdowns

Condition	A	B
Overspeed		X
Unit shutdown		X
Operation of spare lube-oil pump	X	
Failure of cylinder lubricator	X	
High winding temperature		X
High bearing temperature		X
High rod packing temperature		X
High lube-oil-filter differential pressure	X	
High or low lube-oil temperature	X	
High or low lube-oil reservoir level	X	
Low lube-oil pressure		X
Low pressure of frame lubrication system		X

Note: A = annunciated alarm; B = annunciated shutdown.

equipped with valved test connections so that a portable test pump can be used to raise the pressure.

3.4.5.3.5 The vendor shall furnish with the proposal a complete description of the alarm and shutdown facilities to be provided.

3.4.5.4 Replacement of Instruments and Controls

Unless otherwise specified, all instruments and controls other than shutdown sensing devices shall be installed with sufficient valving to permit their replacement while the system is in operation. When shutoff valves are specified for shutdown sensing devices, the vendor shall provide a means of locking the valves in the open position.

3.4.5.5 Housings for Arcing-Type Switches

Particular attention is called to the requirements of 2.1.8 concerning the characteristics of housings for arcing-type switches outlined in the applicable codes.

3.4.6 ELECTRICAL SYSTEMS

- **3.4.6.1** The characteristics of electrical power supplies for motors, heaters, and instrumentation will be specified. A pilot light shall be provided on the incoming side of each supply circuit to indicate that the circuit is energized. The pilot lights shall be installed on the control panels.

3.4.6.2 Electrical equipment located on the unit or on any separate panel shall be suitable for the hazard classification specified. Electrical starting and supervisory controls may be either AC or DC.

3.4.6.3 Power and control wiring within the confines of the baseplate shall be resistant to oil, heat, moisture, and abrasion. Stranded conductors shall be used within the confines of the baseplate and in other areas subject to vibration. Measurement and remote-control panel wiring may be solid conductor. Thermoplastic insulation shall be used and shall be covered by a Neoprene or equal sheath for abrasion protection. Wiring shall be suitable for environmental temperatures.

3.4.6.4 Unless otherwise specified, all leads on terminal strips, switches, and instruments shall be permanently tagged for identification. All terminal boards in junction boxes and control panels shall have at least 20 percent spare terminal points.

3.4.6.5 To facilitate maintenance, liberal clearances shall be provided for all energized parts (such as terminal blocks and relays) on equipment. The clearances required for 600-volt service shall also be provided for lower voltages. Enclosures shall be provided for all energized parts to guard against accidental contact.

- **3.4.6.6** Electrical materials including insulation shall be corrosion resistant and nonhygroscopic insofar as is possible. When tropical location is specified, materials shall be given the treatments specified in 3.4.6.6.1 and 3.4.6.6.2.

3.4.6.6.1 Parts (such as coils and windings) shall be protected from fungus attack.

3.4.6.6.2 Unpainted surfaces shall be protected from corrosion by plating or another suitable coating.

3.4.6.7 Control, instrumentation, and power wiring (including temperature element leads) within the limits of the baseplate shall be installed in rigid metallic conduits and boxes, properly bracketed to minimize vibration and isolated or shielded to prevent interference between voltage levels. Conduits may terminate (and in the case of temperature element heads, shall terminate) with a flexible metallic conduit long enough to permit access to the unit for maintenance without removal of the conduit. If temperature element heads will be exposed to temperatures above 60°C (140°F), a 20 mm (¾ inch) bronze hose with four-wall interlocking construction and joints with packed-on (heatproof) couplings shall be used.

3.4.6.8 For Division 2 locations, flexible metallic conduits shall have a liquid-tight thermosetting or thermoplastic outer jacket and approved fittings. For Division 1 locations, an NFPA-approved connector shall be provided.

3.4.6.9 AC and DC circuits shall be clearly labeled, connected to separate terminal blocks, and isolated from each other.

3.5 Piping

3.5.1 GENERAL

3.5.1.1 Piping design and joint fabrication, examination, and inspection shall be in accordance with ASME B31.3.

3.5.1.2 Auxiliary systems are defined as piping systems that are in the following services.

- a. Group I:
 1. Gland and flushing fluid.
 2. Fuel gas or oil.
 3. Drains and vents.
- b. Group II:
 1. Sealing steam.
 2. Instrument and control air.
 3. Starting air.
 4. Drains and vents.
- c. Group III:
 1. Cooling water.
 2. Drains and vents.
- d. Group IV:
 1. Lubricating oil.
 2. Control oil.
 3. Drains and vents.

Auxiliary systems shall comply with the requirements of Table 4.

Note: Casing connections are discussed in 2.5.

3.5.1.3 Piping systems shall include piping, isolating valves, control valves, relief valves, pressure reducers, orifices, temperature gauges and thermowells, pressure gauges, sight flow indicators, and all related vents and drains.

3.5.1.4 The vendor shall furnish all piping systems, including mounted appurtenances, located within the confines of the main unit's base area, any oil console base area, or any auxiliary base area. The piping shall terminate with flanged connections at the edge of the base. When sole-plates are specified for the equipment train, the extent of the piping system at the equipment train shall be defined by the purchaser. The purchaser will furnish only interconnecting piping between equipment groupings and off-base facilities.

3.5.1.5 The design of piping systems shall achieve the following:

- a. Proper support and protection to prevent damage from vibration or from shipment, operation, and maintenance.
- b. Proper flexibility and normal accessibility for operation, maintenance, and thorough cleaning.
- c. Installation in a neat and orderly arrangement adopted to the contour of the machine without obstruction of access openings.
- d. Elimination of air pockets by the use of valved vents or nonaccumulating piping arrangements.
- e. Complete drainage through low points without disassembly of piping.

3.5.1.6 Piping shall preferably be fabricated by bending and welding to minimize the use of flanges and fittings. Welded flanges are permitted only at equipment connections, at the edge of any base, and for ease of maintenance. The use of flanges at other points is permitted only with the purchaser's specified approval. Other than tees and reducers, welded fittings are permitted only to facilitate pipe layout in congested areas. Threaded connections shall be held to a minimum. Pipe bushings shall not be used.

3.5.1.7 Pipe threads shall be taper threads in accordance with ASME B1.20.1. Alternately, pipe threads in accordance with ISO 228 Part 1 are acceptable when required for compliance with local standards. Flanges shall be in accordance with ISO 7005 (ASME B16.5.) Slip-on flanges are permitted only with the purchaser's specific approval. For socket-welded construction, a 1.5 mm ($\frac{1}{16}$ inch) gap shall be left between the pipe end and the bottom of the socket.

3.5.1.8 Connections, piping, valves, and fittings that are 30 mm ($1\frac{1}{4}$ inches), 65 mm ($2\frac{1}{2}$ inches), 90 mm ($3\frac{1}{2}$ inches), 125 mm (5 inches), 175 mm (7 inches), or 225 mm (9 inches) in size shall not be used.

3.5.1.9 Where space does not permit the use of NPS $\frac{1}{2}$, $\frac{3}{4}$, or 1 pipe, seamless tubing may be furnished in accordance with Table 4.

3.5.1.10 Unless otherwise approved by the purchaser, the minimum size of any connection shall be NPS $\frac{1}{2}$.

3.5.1.11 Piping systems furnished by the vendor shall be fabricated, installed in the shop, and properly supported. Bolted holes for flanged connections shall straddle lines parallel to the main horizontal or vertical centerline of the equipment.

3.5.1.12 Welding shall be performed by operators and procedures qualified in accordance with Section IX of the ASME Code.

3.5.1.13 Pipe plugs shall be in accordance with 2.5.5.

3.5.2 OIL PIPING

3.5.2.1 Oil drains shall be sized to run no more than half full when flowing at a velocity of 0.3 m/s (1 fps) and shall be arranged to ensure good drainage (recognizing the possibility of foaming conditions). Horizontal runs shall slope continuously, at least 1:24, toward the reservoir. If possible, laterals (not more than one in any transverse plane) should enter drain headers at 45-degree angles in the direction of the flow.

3.5.2.2 Nonconsumable backup rings and sleeve-type joints shall not be used. Pressure piping downstream of oil filters shall be free from internal obstructions that could accumulate dirt. Socket-welded fittings shall not be used in pressure piping downstream of oil filters (Table 4).

3.5.2.3 Unless otherwise specified, oil-supply piping, including fittings (excluding slip-on flanges), shall be stainless steel (Table 4).

3.5.3 INSTRUMENT PIPING

3.5.3.1 The vendor shall supply all necessary piping, valves, and fittings for instruments and instrument panels (3.4.3.2).

3.5.3.2 Connections on equipment and piping for pressure instruments and test points shall conform to 3.5.1.4. Beyond the initial NPS $\frac{1}{4}$ isolating valve, NPS $\frac{1}{2}$ piping, valves, and fittings may be used. Where convenient, a common connection may be used for remotely mounted instruments that measure the same pressure. Separate secondary NPS $\frac{1}{2}$ isolating valves are required for each instrument on a common connection. Where a pressure gauge is to be used for testing pressure alarm or shutdown switches, common connections are required for the pressure gauge and switches.

3.5.4 PROCESS PIPING

- **3.5.4.1** The extent of and requirements for process piping to be supplied by the vendor will be specified.

Table 4—Minimum Requirements for Piping Materials

System	Group I (Auxiliary Process Fluid)		Group II (Steam)		Group III (Cooling Water)		Group IV (Lubricating and Control Oil)			
	Nonflammable/ Nontoxic	Flammable/Toxic	≤5.2 bar gauge (75 psig)	>5.2 bar gauge (75 psig)	Seamless ^a	Seamless ^a	Standard (≤ NPS 1)	Optional	≤ NPS 1	≥ NPS 1½
Pipe (schedule)	Seamless ^a	Seamless ^{a,b}	Seamless ^a	Seamless ^a	Seamless ^a	Seamless ^a	Seamless ^a	ASTM A 120, Schedule 40, galvanized to ASTM A 153	ASTM A 312, Type 304 or 316 stainless steel (3.6.2.3) ^b	ASTM A 312, Type 304 or 316 stainless steel (3.6.2.3) ^b
Tubing ^c	Seamless ASTM A 269 stainless steel or ASTM A 192 steel	Seamless ASTM A 269 stainless steel or ASTM A 192 steel	Seamless ASTM A 269 stainless steel or ASTM A 192 steel	Seamless ASTM A 269 stainless steel	Seamless ASTM A 269 stainless steel or ASTM A 192 steel	Seamless ASTM A 269 stainless steel	Seamless ASTM A 269 stainless steel or ASTM A 192 steel	Seamless ASTM A 269 stainless steel or ASTM A 192 steel	Seamless ASTM A 269 stainless steel	—
All valves	Class 800	Class 800	Class 800	Class 800	Class 800	Class 200, bronze	Class 200, bronze	Class 200, bronze	Carbon steel, Class 800	Carbon steel, Class 800
Gate and globe valves ^d	Bolted bonnet and gland	Bolted bonnet and gland	Bolted bonnet and gland	Bolted bonnet and gland	Bolted bonnet and gland	—	—	—	Bolted bonnet and gland	Bolted bonnet and gland
Pipe fittings and unions	Forged, Class 3000	Forged, Class 3000	Forged, Class 3000	Forged, Class 3000	Forged, Class 3000	ASTM A 338 and A 197, Class 150 malleable iron, galvanized to ASTM A 153	ASTM A 338 and A 197, Class 150 malleable iron, galvanized to ASTM A 153	ASTM A 338 and A 197, Class 150 malleable iron, galvanized to ASTM A 153	Stainless steel (3.6.2.2)	Stainless steel (3.6.2.2)
Tube fittings	Manufacturer's standard (with purchaser's approval)	Manufacturer's standard (with purchaser's approval)	Manufacturer's standard (with purchaser's approval)	Manufacturer's standard (with purchaser's approval)	Manufacturer's standard (with purchaser's approval)	Manufacturer's standard (with purchaser's approval)	Manufacturer's standard (with purchaser's approval)	Manufacturer's standard (with purchaser's approval)	Manufacturer's standard (with purchaser's approval)	—
Fabricated joints ≤1½ inches	Threaded	Socket welded Threaded ^e	Threaded	Threaded	Socket welded Threaded ^e	Threaded	Threaded	Threaded	—	Carbon steel slip-on flange
Fabricated joints ≥2 inches	—	—	—	—	—	Purchaser to specify	Purchaser to specify	Purchaser to specify	—	Carbon steel slip-on flange
Gaskets	Type 304 or 316 stainless steel, spiral wound	Type 304 or 316 stainless steel, spiral wound	Type 304 or 316 stainless steel, spiral wound	Type 304 or 316 stainless steel, spiral wound	Type 304 or 316 stainless steel, spiral wound	—	—	—	—	Type 304 or 316 stainless steel, spiral wound
Flange bolting ^f	ASTM A 193, Grade B7 ASTM A 194, Grade 2H	ASTM A 193, Grade B7 ASTM A 194, Grade 2H	ASTM A 193, Grade B7 ASTM A 194, Grade 2H	ASTM A 193, Grade B7 ASTM A 194, Grade 2H	ASTM A 193, Grade B7 ASTM A 194, Grade 2H	—	—	—	ASTM A 193, Grade B7 ASTM A 194, Grade 2H	—

Note: Carbon steel piping shall conform to ASTM A 106, Grade B; ASTM A 524; or API Specification 5L, Grade A or B. Carbon steel fittings, valves, and flanged components shall conform to ASTM A 105 and A 181. Stainless steel piping shall be seamless in accordance with ASTM 312 or electric-fusion welded.

^aSchedule 160 carbon steel for NPS ½ and smaller; Schedule 80 for NPS 1–1½; Schedule 40 for NPS 2 and larger.

^bSchedule 80S stainless steel for NPS 1 and smaller; Schedule 40S for NPS 1½ and 3; Schedule 10S for NPS 4 and larger.

^cFor primary ANSI service pressure ratings above 62 bar gauge (900 psig), block valves may be of welded-bonnet or no-bonnet construction with a bolted gland. These valves shall be suitable for repacking under pressure.

^dThreaded joints require seal welding; however, seal welding is not permitted on cast iron equipment, on instruments, or where disassembly is required for maintenance. Seal-welded joints shall be made in accordance with ASME B31.3.

^eBolting shall be in accordance with 2.4.5.

3.5.4.2 The requirements of 3.5.1 shall apply to process piping supplied by the vendor.

- **3.5.4.3** When specified, the vendor shall review all piping, appurtenances (pulsation suppression devices, intercoolers, aftercoolers, separators, and expansion joints), and vessels immediately upstream and downstream of the equipment and supports. The purchaser and the vendor shall mutually agree on the scope of this review. The vendor shall advise the purchaser on the basis of his knowledge and experience of any hazards in the use, sizing, arrangement, or the like, that may result in damage to the equipment.

3.6 Pulsation and Vibration Control Requirements

3.6.1 GENERAL

3.6.1.1 The interaction of the dynamic flow generated by the pump plungers with acoustical resonances in piping systems can result in high-pressure pulsation levels in the pump and piping, cavitation, excessive vibrations and failures. The pulsation characteristics of a piping system are dependent upon the complexity of the system layout, number of pumps, operating speeds, fluid properties and other factors such as, but not limited to, the following:

- a. Pump type.
- b. Pump size (power).
- c. Number of plungers.
- d. Speed range.
- e. Pumped fluid properties.
- f. System operational conditions.
- g. Piping layout.

3.6.1.2 The basic techniques used for control of detrimental pulsations and vibrations are the following:

- a. Pulsation control devices such as dampeners, accumulators, dampers, preventers, hydraulic isolators, inhibitors, suppressors, stabilizers, acoustic filters, and selected piping configurations.
- b. System design based on studies of the interactive effects of pulsations and the attenuation requirements for satisfactory piping vibration, pump performance, and valve life.
- c. Mechanical restraints including such things as type, location, and number of pipe hold-downs.

Note: Normally, control of system pulsation, cavitation, and vibration requires the coordination of the pump manufacturer and the piping system designer in order to ensure that the complete system is suitable for the intended purpose.

3.6.2 PULSATION DESIGN APPROACHES

- **3.6.2.1** The purchaser will specify the design approach for pulsation and vibration control as defined in Appendix E. The purchaser will also indicate when existing pumps and their associated piping are to be included in the acoustical simulation. There are two general techniques (design

approaches) normally used for control of detrimental pulsations and vibrations.

Note: When deciding which design approach should be used, the purchaser should consider such things as horsepower, economics, piping layout, reliability, documentation requirements, and experience with similar pumps and installations.

Design Approach 1: This approach involves pulsation and vibration control through the use of good piping layout and support/restraint principles, adequate suction pressure (NPSHA), and/or the use of pulsation control devices.

Design Approach 1 does not require an acoustical simulation of the pump and piping system and can be used when experience with similar systems indicates that the likelihood of successful operation is sufficient to justify no acoustical simulation.

Note: Cavitation problems in pump systems are significantly influenced by pulsations; therefore, suction-head assessment based on acceleration head calculations, which is a quasi-static method of considering pulsations in piping systems, may not ensure adequate NPSHA.

Design Approach 2: This approach involves pulsation control through the use of pulsation control devices developed using proven acoustical simulation techniques in conjunction with mechanical analysis of pipe runs and support systems (clamp design and spacing) to achieve control of vibrational response. Design Approach 2 is normally applicable to critical pump and piping systems, multiple pumps in parallel, and applications utilizing variable speed, multiple fluids, and variable operating conditions, where safety and reliability are important, and where suitability of purpose must be documented.

The acoustical characteristics of the entire pump system, including the pump and all important interconnecting piping shall be simulated. The simulation techniques shall be capable of modeling the pulsation-generating mechanisms known to cause pump pulsation and shall be capable of predicting pulsation and shaking force amplitudes throughout the pump and piping system. The simulation techniques shall be capable of evaluating the effectiveness of selected pulsation control devices and/or developing effective acoustical surge volumes, Helmholtz-type acoustic filters, and so forth, if required.

Note: Pump valve dynamic effects, such as lag, lift, spring preload and stiffness, and valve areas, may have a significant influence on pulsation amplitudes and therefore should be considered in the acoustical simulation.

The acoustical simulation techniques shall also be capable of predicting the potential for cavitation and the required minimum suction pressure to prevent cavitation, based on the amplitudes of the pulsations.

Note: When the acoustical simulation is performed, acceleration head pressure calculations are not required since the complex pressure wave at the plungers determined by the simulation method more accurately represents the requirements in fluid head required to fill the working chamber.

Design Approach 2, in conjunction with the pulsation simulation, shall include a mechanical evaluation of the

piping system to ensure that the piping will have adequate supports and clamps to maintain the mechanical natural frequencies above the highest frequency of major acoustical energy. The required spacing and clamp types to ensure non-resonant piping systems shall be determined by the simulation. The mechanical analysis shall ensure that the piping vibration-induced stresses are less than the endurance limit of the piping material with an adequate safety factor.

3.6.2.2 Maximum allowable pulsation involves the following:

3.6.2.2.1 For Design Approach 2, the peak-to-peak pulsation levels in the suction and discharge piping systems beyond the pulsation control devices shall not exceed the levels calculated by Equation 3-1 which specifies the allowable peak-to-peak pulsation level of each individual pulsation frequency component.

$$P_1 = \frac{3500}{(ID \times f)^{1/2}} \quad (3-1)$$

Or, in U.S. Customary Units:

$$P_1 = \frac{100}{(ID \times f)^{1/2}}$$

Where:

P_1 = maximum allowable pulsation level in kPa (psi), peak-to-peak of individual pulsation components corresponding to the fundamental and harmonic frequencies.

Note: Suction and discharge pulsation levels have to be limited to values that will not cause cavitation or relief valve lifting.

ID = inside diameter of line pipe, in millimeters (inches).

f = pulsation frequency, in Hertz, derived from the following equation, in which rpm is pump speed and $n = 1, 2, 3, \dots$, corresponding to the fundamental frequency and harmonics thereof:

$$f = \frac{(rpm)n}{60} \quad (3-2)$$

3.6.2.2.2 Unless otherwise specified, the maximum suction complex pressure wave amplitude (Figure 3) shall not exceed the value calculated using Equation 3-2.

$$P_2 < 1.5(P_s - P_v)$$

Where:

P_v = vapor pressure of the pumped fluid, in kPa abs (psia).

P_s = average suction pressure, in kPa abs (psia).

P_2 = complex pressure wave, in kPa (psi).

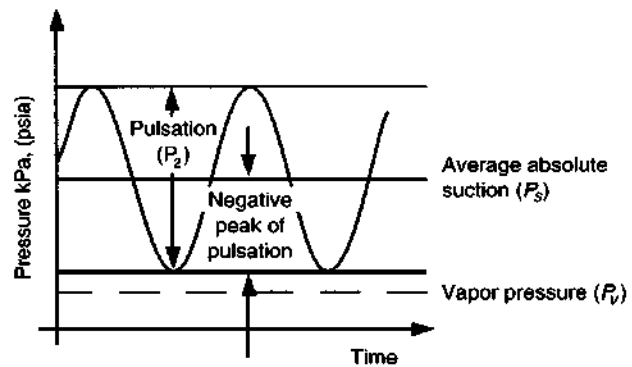

Figure 3—Suction

Note: The theoretical maximum amplitude of the suction pulsation occurs when the negative peak of the pulsation complex wave equals the average suction pressure minus the vapor pressure. Equation 3-2 provides for a margin of safety between the negative peak of pulsation and vapor pressure.

3.6.2.2.3 Unless otherwise specified, the margin of separation between the positive peak of the pulsation complex wave at the relief valve and the relief valve setting shall be 5 percent of the maximum specified discharge pressure or 165 kPa (25 psi), whichever is greater (Figure 4).

$$P_p \leq P_R - P_D - (0.05 \times P_D)^* \quad (3-3)$$

*[or 165 kPa (25 psi) whichever is greater]

Where:

P_p = Positive peak of pulsation complex wave, in kPa (psi).

P_D = The maximum specified value of average discharge pressure, in kPa gauge (psig).

P_R = Required relief valve setting, in kPa gauge (psig).

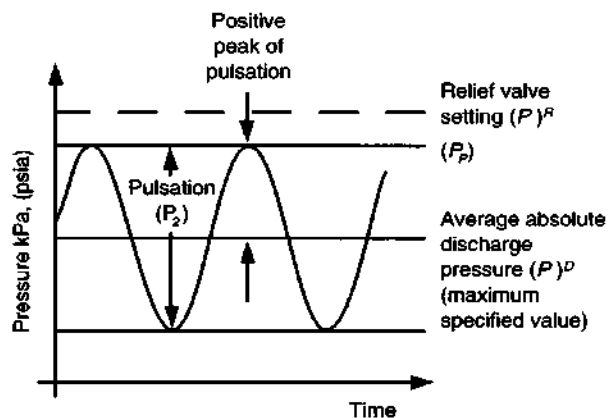

Figure 4—Discharge

3.7 Special Tools

3.7.1 When special tools and fixtures are required to disassemble, assemble, or maintain the unit, they shall be included in the quotation and furnished as part of the initial supply of the machine. For multiple unit installations, the requirements for quantities of special tools and fixtures shall

be mutually agreed upon by the purchaser and the vendor. These or similar special tools shall be used during shop assembly and post-test disassembly of the equipment.

3.7.2 When special tools are provided, they shall be packaged in separate, rugged metal boxes and marked "special tools for (tag/item number)." Each tool shall be stamped or tagged to indicate its intended use.

SECTION 4—INSPECTION, TESTING, AND PREPARATION FOR SHIPMENT

4.1 General

● **4.1.1** The purchaser will specify the extent of participation in the inspection and testing and the amount of advanced notification required.

● **4.1.2** When specified, the purchaser's representative, the vendor's representative, or both, shall indicate compliance in accordance with the inspector's checklist (Appendix C) by initialing, dating, and submitting the completed checklist to the purchaser before shipment.

4.1.3 After advance notification of the vendor by the purchaser, the purchaser's representative shall have entry to all vendor and subvendor plants where manufacturing, testing, or inspection of the equipment is in progress.

4.1.4 The vendor shall notify subvendors of the purchaser's inspection and testing requirements.

4.1.5 The vendor shall provide sufficient advance notice to the purchaser before conducting any inspection or test that the purchaser desires to be witnessed or observed.

4.1.5.1 When shop inspection and testing have been specified by the purchaser, the purchaser and the vendor shall meet to coordinate manufacturing hold points and inspectors' visits.

4.1.5.2 *Witnessed* means that a hold shall be applied to the production schedule and that the inspection or test shall be carried out with the purchaser or his representative in attendance. For mechanical running or performance tests, a witnessed test requires written notification of a successful preliminary test.

4.1.5.3 *Observed* means that the purchaser shall be notified of the timing of the inspection or test; however, the inspection or test shall be performed as scheduled, and if the purchaser or his representative is not present, the vendor shall proceed to the next step.

Note: The purchaser should expect to be in the factory longer than for a witnessed test.

4.1.6 Equipment for the specified inspection and tests shall be provided by the vendor.

4.1.7 The purchaser's representative shall have access to the vendor's quality program for review.

4.2 Inspection

4.2.1 GENERAL

4.2.1.1 The vendor shall keep the following data available for at least twenty years for examination or reproduction by the purchaser or his representative upon request:

- a. Necessary certification of materials, such as mill test reports.
- b. Test data to verify that the requirements of the specification have been met.
- c. Results of documented tests and inspections, including fully identified records of all heat treatment and non-destructive testing.
- d. When specified, final-assembly maintenance and running clearances.

4.2.1.2 Pressure-containing parts shall not be painted until the specified inspection of the parts is completed.

● **4.2.1.3** In addition to the requirements of 2.10.4.1, the purchaser may specify the following:

- a. Parts that shall be subjected to surface and subsurface examination.
- b. The type of examination required, such as magnetic particle, liquid penetrant, radiographic, and ultrasonic examination.

4.2.2 MATERIAL INSPECTION

● 4.2.2.1 General

When radiographic, ultrasonic, magnetic particle or liquid penetrant inspection of welds or materials is required or specified, the criteria in 4.2.2.2 through 4.2.2.5 shall apply unless other criteria are specified by the purchaser. Cast iron may be inspected in accordance with 4.2.2.4 and 4.2.2.5. Welds, cast steel, and wrought material may be inspected in accordance with 4.2.2.2 through 4.2.2.5.

4.2.2.2 Radiography

4.2.2.2.1 Radiography shall be in accordance with ASTM E 94 and ASTM E 142.

4.2.2.2.2 The acceptance standard used for welded fabrications shall be Section VIII, Division 1, UW-51 (100

percent) and UW-52 (spot), of the ASME Code. The acceptance standard used for castings shall be Section VIII, Division 1, Appendix 7, of the ASME Code.

4.2.2.3 Ultrasonic Inspection

4.2.2.3.1 Ultrasonic inspection shall be in accordance with Section V, Articles 5 and 23, of the ASME Code.

4.2.2.3.2 The acceptance standard used for welded fabrications shall be Section VIII, Division 1, Appendix 12, of the ASME Code. The acceptance standard used for castings shall be Section VIII, Division 1, Appendix 7, of the ASME Code.

4.2.2.4 Magnetic Particle Inspection

4.2.2.4.1 Both wet and dry methods of magnetic particle inspection shall be in accordance with ASTM E 709.

4.2.2.4.2 The acceptance standard used for welded fabrications shall be Section VIII, Division 1, Appendix 6 and Section V, Article 25, of the ASME Code. The acceptability of defects in castings shall be based on a comparison with the photographs in ASTM E 125. For each type of defect, the degree of severity shall not exceed the limits specified in Table 5.

4.2.2.5 Liquid Penetrant Inspection

4.2.2.5.1 Liquid penetrant inspection shall be in accordance with Section V, Article 6, of the ASME Code.

4.2.2.5.2 The acceptance standard used for welded fabrications shall be Section VIII, Division 1, Appendix 8, and Section V, Article 25, of the ASME Code. The acceptance standard used for castings shall be Section VIII, Division 1, Appendices 7 and 24, of the ASME Code.

Note: Regardless of the generalized limits in 4.2.2, it shall be the vendor's responsibility to review the design limits of the equipment in the event that more stringent requirements are necessary. Defects that exceed the limits imposed in 4.2.2 shall be removed to meet the quality standards cited, as determined by the inspection method specified.

4.2.3 MECHANICAL INSPECTION

4.2.3.1 During assembly of the equipment and before testing, each component (including cast-in passages of these

components) and all piping and appurtenances shall be cleaned chemically or by another appropriate method to remove foreign materials, corrosion products, and mill scale.

4.2.3.2 Any portion of the oil system furnished shall meet the cleanliness requirements of API Std 614.

● **4.2.3.3** When specified, the purchaser may inspect for cleanliness the equipment and all piping and appurtenances furnished by or through the vendor before heads are welded to vessels, openings in vessels or exchangers are closed, or piping is finally assembled.

● **4.2.3.4** When specified, the hardness of parts, welds, and heat-affected zones shall be verified as being within the allowable values by testing of the parts, welds, or heat-affected zones. The method, extent, documentation, and witnessing of the testing shall be mutually agreed upon by the purchaser and the vendor.

4.3 Tests

4.3.1 TESTING

4.3.1.1 Equipment shall be tested in accordance with 4.3.2, 4.3.3, and 4.3.4. Other tests that may be specified are described in 4.3.1.4.

4.3.1.2 At least six weeks before the first scheduled running test, or at some mutually agreed upon time, the vendor shall submit to the purchaser for his review and comment detailed procedures for all running tests, including acceptance criteria for all monitored parameters.

4.3.1.3 The vendor shall notify the purchaser not less than five working days before the date the equipment will be ready for testing. If the testing is rescheduled, the vendor shall notify the purchaser not less than five working days before the new test date.

● **4.3.1.4** When specified, the tests in Items a through f below shall be performed on the pump.

- a. Performance test in accordance with 4.3.3 or 4.3.4.
- b. Observed or witnessed hydrostatic test.
- c. Observed or witnessed running performance test.
- d. Unwitnessed, observed, or witnessed NPSH test in accordance with 4.3.6.
- e. Dismantling, inspection, and reassembly of liquid end after running test if not needed to satisfy the requirement of 4.3.4.4.
- f. Other tests not listed or defined herein to be completely described in the inquiry and the purchase order.

4.3.2 HYDROSTATIC TEST

4.3.2.1 Pressure-containing parts (including auxiliaries) shall be tested hydrostatically with liquid at a minimum of one and one-half times the maximum allowable working pressure but not less than 1.5 bar gauge (20 psig). The test

Table 5—Maximum Severity of Defects in Castings

Type	Defect	Maximum Severity Level
I	Linear discontinuities	1
II	Shrinkage	2
III	Inclusions	2
IV	Chills and chaplets	1
V	Porosity	1
VI	Welds	1

liquid shall be at a higher temperature than the nil-ductility transition temperature of the material being tested.

4.3.2.2 If the part tested is to operate at a temperature at which the strength of a material is below the strength of the material at room temperature, the hydrostatic test pressure shall be multiplied by a factor obtained by dividing the allowable working stress for the material at room temperature by that at operating temperature. The stress values used shall conform to those given in ASME B31.3 for piping or in Section VIII, Division 1, of the ASME Code for vessels. The pressure thus obtained shall then be the minimum pressure at which the hydrostatic test shall be performed. The data sheet shall list actual hydrostatic test pressures.

4.3.2.3 Where applicable, tests shall be in accordance with the ASME Code. In the event that a discrepancy exists between the code test pressure and the test pressure in this standard, the high pressure shall govern.

4.3.2.4 The chloride content of liquids used to test austenitic stainless steel materials shall not exceed 50 parts per million. To prevent deposition of chlorides as a result of evaporative drying, all residual liquid shall be removed from tested parts at the conclusion of the test.

4.3.2.5 Tests shall be maintained for a sufficient period of time to permit complete examination of parts under pressure. The hydrostatic test shall be considered satisfactory when neither leaks nor seepage through the fluid cylinder or cylinder joint is observed for a minimum of 30 minutes. Large, heavy castings may require a longer testing period to be agreed upon by the purchaser and the vendor. Seepage past internal closures required for testing of segmented cylinders and operation of a test pump to maintain pressure are acceptable.

4.3.2.6 All water side cooling passages shall be tested at a minimum of 8 bar gage (115 psig) (2.1.5.1).

4.3.3 PERFORMANCE TEST, DIRECT-ACTING PUMP

4.3.3.1 Unless otherwise specified, tests shall be conducted in accordance with the standards of the Hydraulic Institute. The manufacturer shall operate the pump in his shop for a sufficient period to obtain complete test data, including speed, discharge pressure, suction pressure, and capacity.

4.3.3.2 The pump shall be operated at speeds within five percentage points of 25, 50, 75, 100, and 125 percent of the rated speed.

4.3.3.3 The pump shall be operated at pressures as near the rated pressures as permitted by the test facility.

4.3.3.4 During the shop tests, the pump shall operate smoothly over the specified operating range, except when running under cavitating conditions during the NPSH test.

4.3.3.5 At rated speed, the pump efficiency shall equal or exceed the quoted efficiency.

4.3.4 PERFORMANCE TEST, POWER PUMP

4.3.4.1 Unless otherwise specified, tests shall be conducted in accordance with the standards of the Hydraulic Institute. The manufacturer shall operate the pump in his shop for sufficient period to obtain complete test data, including speed, discharge pressure, suction pressure, and capacity.

4.3.4.2 The tests specified in 4.3.4.1 apply to the pump only, and the values of power and efficiency are to be taken as referring to the pump. However, the recorded data and final report may include information on the complete unit, including driver and auxiliary equipment.

- **4.3.4.3** When the test facility does not have the capability to meet the rated conditions, the tests may be run at either reduced speed or reduced pressure. When specified, tests shall be run at both the rated discharge pressure with reduced speed and at the rated speed with reduced discharge pressure.

4.3.4.4 If dismantling is necessary to correct pump deficiencies, the pump characteristics affected by the correction shall be reestablished by testing.

4.3.5 TEST TOLERANCES

When operated on the test stand, pumps shall be within the following tolerances of the rated characteristics or the test equivalent.

Characteristic	Tolerance (Percent)	
	Power Pump	Direct-Acting Pump
Rated capacity	+3, -0	+3, -0
Rated power (at rated pressure and capacity)	+4	—
NPSHR	+0	+0

● 4.3.6 NPSH TEST

When specified, the pump shall be tested for NPSH. At rated speed and with NPSHA equal to quoted NPSHR, the pump capacity shall be within three percent of the noncavitating capacity.

Note: Do not run the pump in cavitation.

4.4 Preparation for Shipment

- **4.4.1** Equipment shall be suitably prepared for the type of shipment specified. The preparation shall make the equipment suitable for six months of outdoor storage from the time of shipment, with no disassembly required before operation, except for inspection of bearings. If storage for a longer period is contemplated, the purchaser will consult with the vendor regarding the recommended procedures to be followed.

4.4.2 The vendor shall provide the purchaser with the instructions necessary to preserve the integrity of the storage preparation after the equipment arrives at the jobsite and before startup.

4.4.3 The equipment shall be prepared for shipment after all testing and inspection have been completed and the equipment has been released by the purchaser. The preparation shall include that specified in 4.4.3.1 through 4.4.3.9.

4.4.3.1 Exterior surfaces, except for machined surfaces, shall be given at least one coat of the manufacturer's standard nonlead and nonchromate paint.

4.4.3.2 Exterior machined surfaces, except for corrosion-resistant material, shall be coated with a suitable rust preventive.

4.4.3.3 The interior of the equipment shall be clean; free from scale, welding spatter, and foreign objects; and sprayed or flushed with a suitable rust preventive that can be removed with solvent.

4.4.3.4 Internal steel areas of bearing housings and carbon steel oil systems' auxiliary equipment such as reservoirs, vessels, and piping shall be coated with a suitable oil-soluble rust preventive.

4.4.3.5 Flanged openings shall be provided with metal closures at least 5 mm ($\frac{3}{16}$ inch) thick, with elastomeric gaskets and at least four full-diameter bolts. For studded openings, all nuts needed for the intended service shall be used to secure closures. Each opening shall be seal sealed so that the protective cover cannot be removed without the seal being broken.

4.4.3.6 Threaded openings shall be provided with steel caps or round-head steel plugs. In no case shall nonmetallic (such as plastic) caps or plugs be used.

Note: These are shipping plugs. Permanent plugs are covered in 2.5.5.

4.4.3.7 Lifting points and lifting lugs shall be clearly identified on the equipment or equipment package. The recommended lifting arrangement shall be identified on boxed equipment.

4.4.3.8 The equipment shall be identified with item and serial numbers. Material shipped separately shall be identified with securely affixed corrosion-resistant metal tags indicating the item and serial number of the equipment for which it is intended. In addition, crated equipment shall be shipped with duplicate packing lists, one inside and one on the outside of the shipping container.

4.4.3.9 Exposed shafts and shaft couplings shall be wrapped with waterproof, moldable waxed cloth or volatile-corrosion-inhibitor paper. The seams shall be sealed with oilproof adhesive tape.

4.4.4 Auxiliary piping connections furnished on the purchased equipment shall be impression stamped or permanently tagged to agree with the vendor's connection table or general arrangement drawing. Service and connection designations shall be indicated.

4.4.5 Bearing assemblies shall be fully protected from the entry of moisture and dirt. If vapor-phase-inhibitor crystals in bags are installed in large cavities to absorb moisture, the bags must be attached in an accessible area for ease of removal. Where applicable, bags shall be installed in wire cages attached to flanged covers, and bag locations shall be indicated by corrosion-resistant tags attached with stainless steel wire.

4.4.6 One copy of the manufacturer's standard installation instructions shall be packed and shipped with the equipment.

4.4.7 Connections on auxiliary piping removed for shipment shall be matchmarked for ease of reassembly.

● **4.4.8** When specified, the fit-up and assembly of machine-mounted piping, intercoolers, and so forth shall be completed in the vendor's shop prior to shipment.

SECTION 5—VENDOR'S DATA

5.1 General

5.1.1 The information to be furnished by the vendor is specified in 5.2 and 5.3. The vendor shall complete and forward the Vendor Drawing and Data Requirements (VDDR) form (see Appendix D) to the address(es) noted on the inquiry or order. This form shall detail the schedule for transmission of drawings, curves, and data as agreed to at the time of the proposal or order as well as the number and type of copies required by the purchaser.

5.1.2 The data shall be identified on the transmittal (cover) letters and in the title blocks or title pages with the following information:

- a. The purchaser/user's corporate name.
- b. The job/project number.
- c. The equipment item number and service name.
- d. The inquiry or purchase order number.
- e. Any other identification specified in the inquiry or purchase order.
- f. The vendor's identifying proposal number, shop order number, serial number, or other reference required to completely identify return correspondence.

5.1.3 A coordination meeting shall be held, preferably at the vendor's plant, within 4–6 weeks after the purchase commitment. Unless otherwise specified, the vendor will

prepare and distribute an agenda prior to this meeting which, as a minimum, will include the review of the following items:

- a. The purchase order, scope of supply unit responsibility, and subvendor items.
- b. The data sheets.
- c. Review of applicable specifications and previously agreed-upon exceptions.
- d. Schedules for transmittal of data, production, and testing.
- e. Quality assurance program and procedures.
- f. Inspection, expediting, and testing.
- g. Schematics and bills of material of auxiliary systems.
- h. The physical orientation of the equipment, piping, and auxiliary systems.
- i. Other technical items.

5.2 Proposals

5.2.1 GENERAL

The vendor shall forward the original and the specified number of copies of the proposal to the addressee stated on the inquiry documents. This proposal shall contain as a minimum the data specified in 5.2.2 through 5.2.4 and a specific statement that the system and all its components are in strict accordance with this standard. If the system and components are not in strict accordance, the vendor shall include a specific list that details and explains each deviation. The vendor shall provide details to evaluate any alternative designs proposed. All correspondence shall be clearly identified per 5.1.2.

5.2.2 DRAWINGS

5.2.2.1 The drawings indicated on the VDDR form shall be included. As a minimum, the following data shall be furnished:

- a. A general arrangement or outline drawing for each major skid or system showing overall dimensions, maintenance clearance dimensions, overall weights, erection weights, and maximum maintenance weights (indicated for each piece). Direction of rotation and size and location of major purchaser connections shall also be indicated.
- b. Cross-sectional drawing(s) showing details of the proposed equipment.
- c. Schematics of all auxiliary systems including fuel, lube oil, control, and electrical. Bills of materials shall be included.
- d. Sketches that show methods of lifting the assembled machine(s) and major components.

Note: This information may be included on the drawings specified in Item a. above.

5.2.2.2 If typical drawings, schematics, and bills of material are used, they shall be marked up to show correct weight

and dimension data, and to reflect the actual equipment and scope proposed.

5.2.3 TECHNICAL DATA

The following data shall be included in the proposal:

- a. The purchaser's data sheets with complete vendor's information entered thereon and literature to fully describe details of the offering.
- b. The purchaser's noise data sheet or the form from the appendix of API Standard 615.
- c. The VDDR form with a schedule for transmission of all data specified as part of the contract.
- d. A schedule for shipment of the equipment in weeks after receipt of the order.
- e. A list of major wearing components showing interchangeability with purchaser's other units.
- f. A list of spare parts recommended for startup and normal maintenance purposes.
- g. A list of special tools furnished for maintenance. The vendor shall identify any metric items included in the offering.
- h. A statement of any special weather protection and winterization required for startup, operation, and periods of idleness under the various site conditions specified. The list should show the protection required to be furnished by the purchaser, as well as that included in the vendor's scope of supply.
- i. A complete tabulation of utility requirements such as steam, water, electricity, air, gas, and lube oil, including the quantity of lube oil required and the supply pressure, the heat load to be removed by the oil, and the nameplate power rating and operating power requirements of auxiliary drivers.

Note: Approximate data shall be defined and clearly identified as such.

- j. A description of the tests and inspection procedures for materials as required by 2.10.1.3.
- k. A description of special requirements, as outlined in 2.1.5.1, 2.3.9, 2.3.10, 2.3.11, 2.5.6.4, 2.9.1.3, 2.10.1.2, 2.10.1.9, 2.10.2.5, 2.10.4.2, 3.1.11, 3.4.4.7.2, 3.4.5.3.5, 3.5.4.3, 4.4.1, and any others in purchaser's inquiry.
- l. A list of similar machines installed and operating under analogous conditions to that proposed.
- m. Any startup, shutdown, or operating restrictions required to protect the integrity of the equipment.

5.2.4 CURVES

The vendor shall provide complete performance curves to encompass the map of operations, with any limitations indicated thereon.

5.2.5 OPTIONS

The vendor shall furnish a list of the procedures for any special or optional tests that have been specified by the purchaser or proposed by the vendor.

5.3 Contract Data

5.3.1 GENERAL

5.3.1.1 The contract information to be furnished by the vendor is specified in Appendix D. Each drawing, bill of material, or data sheet shall have a title block in the lower right hand corner with the date of certification, reference to all identification data specified in 5.1.2, revision number and date, and title.

5.3.1.2 The purchaser will promptly review the vendor's data when received; however, this review shall not constitute permission to deviate from any requirements in the order unless specifically agreed upon in writing. After the data has been reviewed, the vendor shall furnish certified copies in the quantity specified.

5.3.1.3 A complete list of all vendor data shall be included with the first issue of major drawings. This list will contain titles, drawing numbers, and a schedule for transmission of all data the vendor will furnish.

5.3.2 DRAWINGS

The drawings furnished shall contain sufficient information so that, with the drawings and manuals specified in 5.3.6, the purchaser may properly install, operate, and maintain the ordered equipment. Drawings shall be clearly legible, shall be identified in accordance with 5.3.1.1, and shall be in accordance with ASME Y14.2M. As a minimum, each drawing shall include the details for that drawing listed in Appendix D.

5.3.3 TECHNICAL DATA

The data shall be submitted in accordance with Appendix D, and identified in accordance with 5.3.1.1. Any comments on the drawing or revisions of specification that necessitate a change in the data shall be noted by the vendor.

Note: These notations will result in the purchaser's issue of the completed, corrected data sheets as part of the order specifications.

5.3.4 PROGRESS REPORTS

The vendor shall submit progress reports to the purchaser at the interval specified on the VDDR form.

5.3.5 PARTS LISTS AND RECOMMENDED SPARES

5.3.5.1 The vendor shall submit complete parts lists for all equipment and accessories supplied. The lists shall include manufacturer's unique part numbers, materials of construction, and delivery times. Materials shall be identified as specified in 2.10.1.2. Each part shall be completely identified and shown on cross-sectional and assembly-type drawings so that the purchaser may determine the interchangeability of the part with other equipment. Parts that have been modified from standard dimensions and/or surface finish to satisfy specific performance requirements shall be uniquely identified

by part number for interchangeability and future duplication purposes. Standard purchased items shall be identified by the original manufacturer's name and part number.

5.3.5.2 The vendor shall indicate on the above parts lists which parts are recommended spares for startup and which parts are recommended for normal maintenance (Item f of 5.2.3). The vendor shall forward the lists to the purchaser promptly after receipt of the reviewed drawings and in time to permit order and delivery of the parts before field startup. The transmittal letter shall be identified with the data specified in 5.1.2.

5.3.6 INSTALLATION, OPERATION, MAINTENANCE, AND TECHNICAL DATA MANUALS

5.3.6.1 General

The vendor shall provide sufficient written instructions and a list of all drawings to enable the purchaser to correctly install, operate, and maintain the complete equipment ordered. This information shall be compiled in a manual (or manuals) with a cover sheet containing all reference-identifying data required in 5.1.2, an index sheet containing section titles, and a complete list of referenced and enclosed drawings by title and drawing number. The manual shall be prepared for the specified installation; a typical manual is not acceptable.

5.3.6.2 Installation Manual

Any special information required for proper installation design that is not on the drawings shall be compiled in a manual that is separate from the operating and maintenance instructions. This manual shall be forwarded at a time that is mutually agreed upon in the order, but not later than the final issue of prints. The manual shall contain information such as special alignment and grouting procedures, utility specifications (including quantity), and all other installation design data, including the drawings and data specified in 5.2.2 and 5.2.3. The manual shall also include sketches that show the location of the center of gravity and rigging provisions to permit the removal of any subassemblies that weigh more than 135 kg (300 pounds).

5.3.6.3 Operating and Maintenance Manual

The manual containing operating and maintenance data shall be forwarded no more than two weeks after all the specified tests have been successfully completed. This manual shall include a section that provides special instructions for operation at specified extreme environmental conditions, such as high or low temperatures. As a minimum, the manual shall include all data shown in Appendix D.

● 5.3.6.4 Technical Data Manual

When specified, the vendor shall provide a technical data manual within 30 days of the completion of shop testing. See Appendix D for detail requirements.

APPENDIX A—RECIPROCATING PUMP DATA SHEETS

RECIPROCATING PUMP DATA SHEET CUSTOMARY UNITS

JOB NO. _____ ITEM NO. _____
 PURCH. ORDER NO. _____ DATE _____
 INQUIRY NO. _____ BY _____
 REVISION _____ DATE _____

1 APPLICABLE TO: PROPOSAL PURCHASE AS BUILT
 2 FOR _____ UNIT _____
 3 SITE _____ NO. OF PUMPS REQUIRED _____
 4 SERVICE _____ SIZE AND TYPE _____
 5 MANUFACTURER _____ SERIAL NO. _____

6 NOTE: INDICATES INFORMATION TO BE COMPLETED BY PURCHASER BY MANUFACTURER

7 **GENERAL**

8 NO. MOTOR DRIVEN _____ OTHER DRIVER TYPE _____
 9 PUMP ITEM NO'S _____ PUMP ITEM NO'S _____
 10 MOTOR ITEM NO'S _____ DRIVER ITEM NO'S _____ GEAR ITEM NO'S _____
 11 MOTOR PROVIDED BY _____ DRIVER PROVIDED BY _____ GEAR PROVIDED BY _____
 12 MOTOR MOUNTED BY _____ DRIVER MOUNTED BY _____ GEAR MOUNTED BY _____
 13 MOTOR DATA SHEET NO. _____ DRIVER DATA SHEET NO. _____ GEAR DATA SHEET NO. _____

14 **OPERATING CONDITIONS** **LIQUID**

<p>15 <input type="radio"/> CAPACITY @ PT (GPM): 16 @ MAXIMUM VISCOSITY _____ @ MINIMUM VISCOSITY _____ 17 <input type="radio"/> DISCHARGE PRESSURE (PSIG): 18 MAXIMUM _____ MINIMUM _____ 19 <input type="radio"/> SUCTION PRESSURE (PSIG): 20 MAXIMUM _____ MINIMUM _____ 21 <input type="radio"/> DIFFERENTIAL PRESSURE (PSI): 22 MAXIMUM _____ MINIMUM _____ 23 <input type="radio"/> NPSH AVAILABLE (FT.) WITHOUT ACCELERATION HEAD _____ 24 <input type="radio"/> ACCELERATION HEAD (APP G) _____ NET _____</p>	<p><input type="radio"/> TYPE OR NAME OF LIQUID _____ <input type="radio"/> PUMPING TEMPERATURE (°F): COMPRESSIBILITY % _____ NORMAL _____ MAXIMUM _____ MINIMUM _____ <input type="radio"/> SPECIFIC GRAVITY _____ MAXIMUM _____ MINIMUM _____ <input type="radio"/> SPECIFIC HEAT _____ Cp (BTU/lb °F) _____ <input type="radio"/> VISCOSITY (SSU) _____ MINIMUM _____ MAXIMUM _____ <input type="radio"/> CORROSIVE/EROSIVE AGENTS _____ <input type="radio"/> CHLORIDE CONCENTRATION (PPM) _____ <input type="radio"/> H₂S CONCENTRATION (PPM) _____ LIQUID <input type="radio"/> TOXIC <input type="radio"/> FLAMMABLE <input type="radio"/> OTHER _____</p>
--	---

25 **PERFORMANCE** **SITE AND UTILITY DATA**

<p>26 <input type="checkbox"/> RATED CAPACITY (GPM) _____ 27 <input type="checkbox"/> NPSH REQUIRED (FT.) _____ 28 <input type="checkbox"/> PISTON SPEED (FPM) _____ 29 <input type="checkbox"/> DISPLACEMENT (GPM) _____ 30 <input type="checkbox"/> VOLUMETRIC EFFICIENCY (%) _____ 31 <input type="checkbox"/> MECHANICAL EFFICIENCY (%) _____ 32 <input type="checkbox"/> BHP @ MAXIMUM VISCOSITY _____ 33 <input type="checkbox"/> BHP @ RELIEF VALVE SETTING _____ 34 <input type="checkbox"/> MAXIMUM ALLOWABLE SPEED (RPM) _____ 35 <input type="checkbox"/> MINIMUM ALLOWABLE SPEED (RPM) _____ 36 <input type="checkbox"/> PINION SHAFT (RPM) _____ 37 <input type="checkbox"/> HYDRAULIC HP _____ BHP _____</p> <p>38 FOR DIRECT-ACTING PUMPS: 39 <input type="radio"/> DRIVE GAS _____ 40 <input type="radio"/> GOVERNOR TYPE _____ 41 <input type="radio"/> INLET PRESSURE (psig) _____ 42 <input type="radio"/> INLET TEMPERATURE (F) _____ 43 <input type="radio"/> EXHAUST PRESSURE (psig) _____ 44 <input type="checkbox"/> STALL PRESSURE (psig) _____ 45 <input type="checkbox"/> GAS CONSUMPTION (lb/hp-hr) _____</p>	<p><input type="radio"/> INDOOR <input type="radio"/> OUTDOOR <input type="radio"/> HEATED <input type="radio"/> UNHEATED <input type="radio"/> UNDER ROOF <input type="radio"/> ELECTRICAL AREA CLASS _____ GROUP _____ DIV _____ <input type="radio"/> WINTERIZATION REQD <input type="radio"/> TROPICALIZATION REQD SITE DATA <input type="radio"/> RANGE OF AMBIENT TEMPS: MIN/MAX _____ / _____ °F UNUSUAL CONDITIONS <input type="radio"/> DUST <input type="radio"/> FUMES <input type="radio"/> SALT ATMOSPHERE <input type="radio"/> OTHER _____ UTILITY CONDITIONS</p> <table border="0" style="width: 100%;"> <tr> <td>ELECTRICITY</td> <td>DRIVERS</td> <td>HEATING</td> <td>CONTROL</td> <td>SHUTDOWN</td> </tr> <tr> <td>VOLTAGE _____</td> <td>_____</td> <td>_____</td> <td>_____</td> <td>_____</td> </tr> <tr> <td>HERTZ _____</td> <td>_____</td> <td>_____</td> <td>_____</td> <td>_____</td> </tr> <tr> <td>PHASE _____</td> <td>_____</td> <td>_____</td> <td>_____</td> <td>_____</td> </tr> </table> <table border="0" style="width: 100%;"> <tr> <td>COOLING WATER</td> <td>INLET</td> <td>RETURN</td> <td>DESIGN</td> <td>MAX Δ</td> </tr> <tr> <td>TEMP °F _____</td> <td>_____</td> <td>_____</td> <td>_____</td> <td>_____</td> </tr> <tr> <td>PRESS. (PSIG) _____</td> <td>MIN _____</td> <td>_____</td> <td>_____</td> <td>_____</td> </tr> <tr> <td>SOURCE _____</td> <td>_____</td> <td>_____</td> <td>_____</td> <td>_____</td> </tr> </table> <p>INSTRUMENT AIR _____ MAX _____ MIN _____ PRESSURE (PSIG) _____</p>	ELECTRICITY	DRIVERS	HEATING	CONTROL	SHUTDOWN	VOLTAGE _____	_____	_____	_____	_____	HERTZ _____	_____	_____	_____	_____	PHASE _____	_____	_____	_____	_____	COOLING WATER	INLET	RETURN	DESIGN	MAX Δ	TEMP °F _____	_____	_____	_____	_____	PRESS. (PSIG) _____	MIN _____	_____	_____	_____	SOURCE _____	_____	_____	_____	_____
ELECTRICITY	DRIVERS	HEATING	CONTROL	SHUTDOWN																																					
VOLTAGE _____	_____	_____	_____	_____																																					
HERTZ _____	_____	_____	_____	_____																																					
PHASE _____	_____	_____	_____	_____																																					
COOLING WATER	INLET	RETURN	DESIGN	MAX Δ																																					
TEMP °F _____	_____	_____	_____	_____																																					
PRESS. (PSIG) _____	MIN _____	_____	_____	_____																																					
SOURCE _____	_____	_____	_____	_____																																					

46 **APPLICABLE SPECIFICATIONS**

47 API 674 POSITIVE DISPLACEMENT PUMPS - RECIPROCATING
 48 GOVERNING SPECIFICATION (IF DIFFERENT) _____

49 REMARKS: _____
 50 _____
 51 _____

**RECIPROCATING PUMP DATA SHEET
CUSTOMARY UNITS**

PAGE _____ OF _____
 JOB NO. _____ ITEM NO. _____
 REVISION _____ DATE _____
 BY _____

CONSTRUCTION

LIQUID END: (2.7.1.1 THROUGH 2.7.1.4)		NOZZLES		SIZE	ANSI RATING	FACING	LOCATION
<input type="checkbox"/> SIMPLEX	<input type="checkbox"/> MULTIPLEX	<input type="checkbox"/> PLUNGER	LIQUID SUCTION	_____	_____	_____	_____
<input type="checkbox"/> DUPLEX	<input type="checkbox"/> NO. OF CYLINDERS	<input type="checkbox"/> PISTON	LIQUID DISCHARGE	_____	_____	_____	_____
<input type="checkbox"/> SINGLE ACTING	<input type="checkbox"/> HORIZONTAL	<input type="checkbox"/> REMOVABLE LINERS	GAS INLET	_____	_____	_____	_____
<input type="checkbox"/> DOUBLE ACTING	<input type="checkbox"/> VERTICAL	<input type="checkbox"/> NO LINERS	GAS EXHAUST	_____	_____	_____	_____
VALVES PER CORNER:			GAND FLUSH	_____	_____	_____	_____
	NUMBER	AREA (In ²)	VELOCITY (fpm)	DRAINS	_____	_____	_____
<input type="checkbox"/> SUCTION	_____	_____	_____	OTHER	_____	_____	_____
<input type="checkbox"/> DISCHARGE	_____	_____	_____	OTHER	_____	_____	_____
VALVE TYPE: <input type="checkbox"/> DISC <input type="checkbox"/> WING <input type="checkbox"/> DOUBLE PORTED <input type="checkbox"/> BALL			OTHER	_____	_____	_____	_____

MATERIALS

PART	LIQUID END	ASTM NO.	GAS END
15 CYLINDER	_____	_____	_____
16 LINER	_____	_____	_____
17 PISTON OR PLUNGER	_____	_____	_____
18 PISTON RINGS	_____	_____	_____
19 PISTON ROD	_____	_____	_____
20 VALVES/VALVE SEATS	_____	_____	_____
21 GLAND	_____	_____	_____
22 THROAT BUSHING	_____	_____	_____
23 PACKING	_____	_____	_____
24 LANTERN RING	_____	_____	_____
25 BOLTING	_____	_____	_____
26 OTHER	_____	_____	_____
27 OTHER	_____	_____	_____

LIQUID END LUBRICATION

PACKING LUBE _____
 FLUSH SOURCE _____
 LUBRICATOR MAKE _____
 SIZE _____ NO. OF FEEDS _____

PACKING

	LIQUID END	GAS END	VALVE ROD
NO. OF RINGS	_____	_____	_____
SIZE OF RINGS	_____	_____	_____
OTHER	_____	_____	_____

PRESSURE RATINGS

	LIQUID CYLINDER	GAS CYLINDER
36 MAXIMUM PRESSURE (psig)	_____	_____
37 MAXIMUM TEMPERATURE (F)	_____	_____
38 HYDROSTATIC TEST PRESSURE (psig)	_____	_____
39 OTHER	_____	_____

QA INSPECTION AND TEST

COMPLIANCE WITH INSPECTORS CHECK LIST
 CERTIFICATION OF MATERIALS
 FINAL ASSEMBLY CLEARANCES
 SURFACE AND SUBSURFACE EXAMINATIONS
 RADIOGRAPHY
 ULTRASONIC
 MAGNETIC PARTICLE
 LIQUID PENETRANT
 CLEANLINESS PRIOR TO FINAL ASSEMBLY
 HARDNESS OF PARTS, WELDS & HEAT AFFECTED ZONES
 FURNISH PROCEDURES FOR OPTIONAL TESTS

TESTS	REQ'D	W/T	OBS
HYDROSTATIC	●	○	○
PERFORMANCE	○	○	○
NPSH	○	○	○
OTHER	○	○	○

DRIVE MECHANISM

DIRECT COUPLED V-BELT OR COG GEAR
 COUPLING MANUFACTURER _____
 SOLEPLATES BASEPLATE SKID
 BY PUMP MANUFACTURER SUITABLE FOR EPOXY GROUT
 EXTENDED FOR _____
 SUBPLATES BY PUMP MANUFACTURER
 DRAIN-RIM DRAIN-PAN
 LEVELING PADS SUITABLE FOR COLUMN MOUNTING

50 REMARKS _____

RECIPROCATING PUMP DATA SHEET CUSTOMARY UNITS

PAGE _____ OF _____

JOB NO. _____ ITEM NO. _____

REVISION _____ DATE _____

BY _____

<p>1 <input type="checkbox"/> POWER FRAME</p> <p>2 MAXIMUM FRAME RATING: _____</p> <p>3 _____ hp @ _____ rpm</p> <p>4 MAXIMUM PRESSURE RATING (psig) _____</p> <p>5 CRANKSHAFT MATERIAL _____</p> <p>6 NO. OF MAIN BEARINGS _____</p> <p>7 TYPE OF MAIN BEARINGS _____</p> <p>8 INTERNAL GEARS? <input type="checkbox"/> YES <input type="checkbox"/> NO</p> <p>9 GEAR RATIO _____</p> <p>10 GEAR SERVICE FACTOR _____</p> <p>11 POWER END LUBRICATION:</p> <p>12 TYPE <input type="radio"/> SPLASH <input type="radio"/> POSITIVE PRESSURE <input type="radio"/> GRAVITY</p> <p>13 OIL PUMP: _____</p> <p>14 MAIN _____</p> <p>15 <input type="radio"/> AUXILIARY _____</p> <p>16 <input type="radio"/> DRIVEN BY _____</p> <p>17 OIL FILTER:</p> <p>18 TYPE _____ <input type="radio"/> MAKE _____</p> <p>19 <input type="checkbox"/> FILTRATION SIZE _____ <input type="radio"/> MODEL _____</p> <p>20 <input type="radio"/> OIL COOLER</p> <p>21 TYPE _____</p> <p>22 SIZE _____</p> <p>23 DRIVERS</p> <p>24 <input type="radio"/> MOTOR</p> <p>25 <input type="checkbox"/> MANUFACTURER _____</p> <p>26 <input type="checkbox"/> TYPE _____</p> <p>27 <input type="checkbox"/> FRAME NO. _____</p> <p>28 <input type="radio"/> CONSTANT SPEED _____</p> <p>29 <input type="radio"/> VARIABLE SPEED _____</p> <p>30 <input type="checkbox"/> KW _____ RPM _____</p> <p>31 <input type="radio"/> VOLTS _____ PHASE _____</p> <p>32 <input type="radio"/> HERTZ _____ SERVICE FACTOR _____</p> <p>33 <input type="radio"/> ENCLOSURE _____</p> <p>34 <input type="radio"/> _____</p> <p>35 <input type="radio"/> STEAM TURBINE</p> <p>36 <input type="radio"/> OTHER (SEE SEPARATE DATA SHEETS) _____</p> <p>37 GEAR REDUCER</p> <p>38 <input type="radio"/> REQUIRED _____</p> <p>39 <input type="checkbox"/> MANUFACTURER _____</p> <p>40 <input type="checkbox"/> MODEL _____</p> <p>41 <input type="checkbox"/> TYPE _____</p> <p>42 <input type="checkbox"/> SERVICE FACTOR _____</p> <p>43 <input type="checkbox"/> RATING _____</p> <p>44 V-BELT OR CHAIN DRIVE</p> <p>45 <input type="radio"/> REQUIRED _____</p> <p>46 <input type="checkbox"/> NO. OF BELTS _____</p> <p>47 <input type="checkbox"/> SIZE OF BELTS _____</p> <p>48 <input type="checkbox"/> CHAIN DETAILS _____</p> <p>49 <input type="radio"/> TOTALLY ENCLOSED GUARD _____</p> <p>50 <input type="radio"/> SLIDE RAILS FOR ADJUSTMENT _____</p> <p>51</p>	<p style="text-align: center;">CONTROLS</p> <p>TYPE:</p> <p><input type="radio"/> MANUAL <input type="radio"/> REMOTE <input type="radio"/> PNEUMATIC</p> <p><input type="radio"/> AUTOMATIC <input type="radio"/> LOCAL <input type="radio"/> ELECTRONIC</p> <p>CAPACITY CONTROL:</p> <p><input type="radio"/> FLOW BYPASS <input type="radio"/> VARIABLE SPEED <input type="radio"/> COMBINATION</p> <p style="padding-left: 40px;"><input type="radio"/> ONLY <input type="radio"/> ONLY</p> <p><input type="radio"/> VENDOR FURNISHES CS GOVERNOR & VALVE</p> <p><input type="radio"/> VENDOR TO FURNISH CONTROL PANEL</p> <p style="padding-left: 40px;"><input type="radio"/> FREESTANDING <input type="radio"/> ON UNIT <input type="radio"/> OTHER _____</p> <p><input type="radio"/> TACHOMETER REQUIRED TYPE _____</p> <p style="text-align: center;">OTHER PURCHASE REQUIREMENTS</p> <p>NAMEPLATE UNITS <input type="radio"/> CUSTOMARY <input type="radio"/> SI</p> <p><input type="radio"/> VENDOR FURNISHED PROCESS PIPING _____</p> <p><input type="radio"/> VENDOR REVIEW PIPING DRAWINGS</p> <p><input type="radio"/> VENDOR FURNISHED PULSATION SUPPRESSION DEVICES</p> <p><input type="radio"/> VENDOR FURNISHED RELIEF VALVE</p> <p><input type="radio"/> INTERNAL <input type="radio"/> EXTERNAL</p> <p><input checked="" type="checkbox"/> RELIEF VALVE SETTING (PSIG)</p> <p><input type="radio"/> LIQUID-FILLED PRESSURE GAUGES REQUIRED</p> <p><input type="radio"/> TECHNICAL DATA MANUAL REQUIRED</p> <p><input type="radio"/> MAXIMUM SOUND PRESSURE LEVEL</p> <p style="padding-left: 40px;">@ _____ FT _____ DBA</p> <p><input type="radio"/> OVERSIZE NOZZLE MATING PARTS BY VENDOR</p> <p><input type="radio"/> QUENCH-TYPE GLANDS REQUIRED</p> <p><input type="radio"/> PROVIDE PACKING COLLECTION CHAMBER</p> <p><input type="radio"/> PROVIDE LANTERN RING PURGE</p> <p style="padding-left: 40px;"><input type="checkbox"/> SIZE _____</p> <p><input type="radio"/> OIL HEATER CONNECTION REQUIRED</p> <p>DISTANCE PIECE COVERS</p> <p style="padding-left: 40px;"><input type="radio"/> SAFETY <input type="radio"/> LOUVERED <input type="radio"/> SOLID</p> <p style="padding-left: 80px;">GUARDS WEATHER COVERS</p> <p style="padding-left: 80px;">COVERS</p> <p>ADDITIONAL OIL SYSTEM ITEMS</p> <p style="padding-left: 40px;"><input type="radio"/> FLOW <input type="radio"/> PRESSURE <input type="radio"/> TEMPERATURE</p> <p style="padding-left: 80px;">INDICATOR GAUGES GAUGES</p> <p style="padding-left: 40px;"><input type="radio"/> STRAINER <input type="radio"/> OTHER _____</p> <p>OIL HEATER REQUIRED</p> <p style="padding-left: 40px;"><input type="radio"/> STEAM <input type="radio"/> ELECTRIC</p> <p><input type="radio"/> MECHANICAL LUBRICATOR REQUIRED</p> <p>MINIMUM DESIGN METAL TEMPERATURE °F _____</p> <p>GEARS COMPLY WITH <input type="radio"/> API 613 <input type="radio"/> API 677</p> <p><input type="radio"/> API 671 COUPLINGS AND GAUGES REQUIRED</p> <p style="text-align: center;">PREPARATION FOR SHIPMENT</p> <p><input type="radio"/> DOMESTIC <input type="radio"/> EXPORT <input type="radio"/> EXPORT BOXING</p> <p><input type="radio"/> OUTDOOR STORAGE MORE THAN 6 MONTHS</p> <p style="text-align: center;">WEIGHTS (LBS)</p> <p><input type="checkbox"/> PUMP _____ <input type="checkbox"/> BASE _____ <input type="checkbox"/> GEAR _____ <input type="checkbox"/> DRIVER _____</p>
--	--

RECIPROCATING PUMP DATA SHEET CUSTOMARY UNITS

PAGE _____ OF _____

JOB NO. _____ ITEM NO. _____

REVISION _____ DATE _____

BY _____

1	PULSATION SUPPRESSION DEVICES FOR RECIPROCATING PUMPS (CONTD)	SERVICE _____
2	THESE SHEETS TO BE FILLED OUT FOR EACH SERVICE AND/OR STAGE	STAGE NO. _____
3	APPLICABLE TO: <input type="radio"/> PROPOSAL <input type="radio"/> PURCHASE <input type="radio"/> AS BUILT	
4	FOR USER _____	
5	SITE LOCATION _____	AMBIENT TEMPERATURE MIN/MAX _____ / _____ °F
6	PUMP SERVICE _____	NUMBER OF PUMPS _____
7	PUMP MFG. _____	MODEL/TYPE _____
8	SUPPRESSOR MFG. _____	
9	NOTE: <input type="radio"/> Data Completed Purch. <input type="checkbox"/> By Pump/Supp. Mfg. w/Proposal <input type="checkbox"/> By Mfg(s) after order <input type="checkbox"/> By Mfg(s)/Purchaser as Applicable	
10	GENERAL INFORMATION APPLICABLE TO ALL SUPPRESSORS	
11	TOTAL NUMBER OF SERVICES AND/OR STAGES _____	
12	<input type="radio"/> ASME CODE STAMP <input type="radio"/> STATE/COUNTRY/PROVINCE OF _____ CODE REGULATIONS APPLY	
13	<input type="radio"/> OTHER APPLICABLE PRESSURE VESSEL SPEC. OR CODE _____	
14	RADIOGRAPHY (X-RAY OF WELDS): <input type="radio"/> NONE <input type="radio"/> SPOT <input type="radio"/> 100% <input type="radio"/> IMPACT TEST <input type="radio"/> SPECIAL WELDING REQUIREMENTS	
15	<input type="radio"/> SHOP INSPECTION <input type="radio"/> OUTDOOR STORAGE OVER 6 MONTHS <input type="radio"/> SPECIAL PAINT SPEC _____	
16	DESIGN APPROACH: <input type="radio"/> 1 W/SIMPLIFIED MANUAL ANALYSIS OF PIPING SYSTEM	
17	<input type="radio"/> 2. ACOUSTIC SIMULATION STUDY	
18	STUDY TO BE WITNESSED: <input type="radio"/> YES <input type="radio"/> NO	
19	HYDROTEST <input type="radio"/> WITNESS	
20	<input type="radio"/> OBSERVE	
21		
22	OPERATING AND SUPPRESSOR DESIGN DATA	
23	<input checked="" type="checkbox"/> PUMP DATA, THIS SERVICE OR STAGE ONLY NOTES:	NUMBER OF CYL. _____ INTERNAL PASSAGES _____
24		BORE DIA _____ IN. STROKE _____ IN. RPM _____
25		PUMP VALVE DATA
26		TYPE _____ LIFT _____ IN WEIGHT _____ OZ.
27		SPRING PRELOAD _____ LB. SPRING RATE _____ LIFT AREA _____
28		FULL PROJECTED AREA _____ EFF. FULL LIFT AREA _____
29		
30	LIQUID HANDLED-SEE DATA SHT PG. 1	NORMAL OPERATING _____
31		<input type="radio"/> CORR. PRESENT (DESCRIBE) _____
32		SPECIFIC GRAVITY _____
33		COMPRESSIBILITY % _____
34		<input type="radio"/> OPERATION IN PARALLEL W/ _____
35	<input type="checkbox"/> PUMP MANUFACTURER'S RATED CAPACITY	GPM _____
36	<input type="checkbox"/> LINE SIDE OPERATING PRESSURE	INLET _____ PSIG DISCHARGE _____ PSIG
37	<input type="checkbox"/> OPERATING TEMP WITHIN SUPPRESSORS	INLET _____ °F <input type="checkbox"/> DISCHARGE _____ °F
38	<input type="checkbox"/> ALLOWABLE PRESSURE DROP THROUGH SUPPRESSORS	ΔP _____ PSI / _____ % ΔP _____ PSI / _____ %
39		INLET SUPPRESSOR DISCHARGE SUPPRESSOR
40	<input type="radio"/> COMBINATION INLET SUPP SEPARATOR/INTERNALS	<input type="radio"/> YES <input type="radio"/> NO / <input type="radio"/> YES <input type="radio"/> NO / <input type="radio"/> YES <input type="radio"/> NO
41	<input type="checkbox"/> NO. (QTY) OF INLET & DISCH. SUPP. PER STAGE	
42	<input type="radio"/> ALLOWABLE PEAK-PEAK PULSE @ LINE SIDE NOZZLE	PSI / % PSI / %
43	<input type="radio"/> ALLOWABLE PEAK-PEAK PULSE @ CYL FLANGE NOZZLE	PSI / % PSI / %
44	<input type="radio"/> MIN. REQ'D WORKING PRESSURE & TEMPERATURE	
45	NOTE: After design, the actual Mawp & temp are to be determined based on the weakest component and stamped on the vessel. The actual Mawp is to be shown on pg. 5 line 11 and on the U1A Forms.	PSIG. @ °F PSIG @ °F
46		
47		
48		
49		
50		
51		

RECIPROCATING PUMP DATA SHEET CUSTOMARY UNITS

PAGE _____ OF _____

JOB NO. _____ ITEM NO. _____

REVISION _____ DATE _____

BY _____

1	PULSATION SUPPRESSION DEVICES FOR RECIPROCATING PUMPS (CONTD)		SERVICE _____	
2	THESE SHEETS TO BE FILLED OUT FOR EACH SERVICE AND/OR STAGE		STAGE NO. _____	
3	CONSTRUCTION REQUIREMENTS & DATA		INLET SUPPRESSOR	
4	<input type="checkbox"/> BASIC MATERIAL REQUIRED, CS, SS, ETC.		DISCHARGE SUPPRESSOR	
5	<input type="checkbox"/> ACT. MAT., ASTM OR SA DESIGNATION SHELL / HEAD	/	/	
6	<input type="checkbox"/> SPECIAL HARDNESS LIMITATIONS R _c <input type="checkbox"/> YES <input type="checkbox"/> NO	SHELL & HEADS	SHELL & HEADS	
7	<input type="checkbox"/> CORROSION ALLOW. (INCHES) <input type="checkbox"/> REQUIRED	WELDS	WELDS	
8	<input type="checkbox"/> WALL THICKNESS, (INCHES) SHELL/HEAD	IN.	IN.	
9	<input type="checkbox"/> NOM. SHELL DIA x OVERALL LGTH. INCH/VOL. FT ³	IN. / IN.	IN. / IN.	
10	<input type="checkbox"/> PIPE OR ROLLED PLATE CONSTRUCTION	x IN. / FT ³	x IN. / FT ³	
11	<input type="checkbox"/> ACT MAX ALLOW. WORKING PRESS AND TEMPERATURE	<input type="checkbox"/> PIPE <input type="checkbox"/> ROLLED PLATE	<input type="checkbox"/> PIPE <input type="checkbox"/> ROLLED PLATE	
12	<input type="checkbox"/> MAX EXPECTED PRESSURE DROP ΔP, PSI % LINE PRESS	PSI @ °F	PSI @ °F	
13	<input type="checkbox"/> WEIGHT, LBS EACH	ΔP PSI / %	ΔP PSI / %	
14	<input type="checkbox"/> INSUL NUTS & ALLOW. FOR INSULATION REQUIRED	LBS	LBS	
15	<input type="checkbox"/> EXPECTED P-P PULSE @ LINE SIDE CYL FLG, % LINE PRESS	<input type="checkbox"/> YES <input type="checkbox"/> NO	<input type="checkbox"/> YES <input type="checkbox"/> NO	
16	BASED ON FINAL SUPPRESSOR DESIGN	% / %	% / %	
17				
18	<input type="checkbox"/> SUPPORTS, TYPE/QUANTITY			
19	CONNECTION REQUIREMENTS & DATA			
20	<input type="checkbox"/> LINE SIDE FLANGE, SIZE RATING/FACING/TYPE			
21	<input type="checkbox"/> PUMP FLANGE(S), QTY: SIZE RATING/FACING/TYPE			
22	<input type="checkbox"/> FLANGE FINISH, <input type="checkbox"/> SPECIAL (SPECIFY)			
23	<input type="checkbox"/> PER ASME 16.5			
24	<input type="checkbox"/> INSPECTION OPENINGS REQUIRED	<input type="checkbox"/> YES <input type="checkbox"/> NO <input type="checkbox"/> BLINDED	<input type="checkbox"/> YES <input type="checkbox"/> NO <input type="checkbox"/> BLINDED	
25	<input type="checkbox"/> SPEC. QTY, SIZE, 6000 LB NPT CPLG, FLG TYPE & RATING			
26	<input type="checkbox"/> *QTY, SIZE, 6000 LB NPT CPLG, FLG TYPE & RATING			
27	<input type="checkbox"/> VENT CONNECTIONS REQUIRED	<input type="checkbox"/> YES <input type="checkbox"/> NO	<input type="checkbox"/> YES <input type="checkbox"/> NO	
28	<input type="checkbox"/> SPEC. QTY, SIZE, 6000 LB NPT CPLG, FLG TYPE & RATING			
29	<input type="checkbox"/> *QTY, SIZE, 6000 LB NPT CPLG, FLG TYPE & RATING			
30	<input type="checkbox"/> DRAIN CONNECTIONS REQUIRED	<input type="checkbox"/> YES <input type="checkbox"/> NO	<input type="checkbox"/> YES <input type="checkbox"/> NO	
31	<input type="checkbox"/> SPEC. QTY, SIZE, 6000 LB NPT CPLG, FLG TYPE & RATING			
32	<input type="checkbox"/> *QTY, SIZE, 6000 LB NPT CPLG, FLG TYPE & RATING			
33	<input type="checkbox"/> PRESSURE CONNECTIONS REQUIRED	<input type="checkbox"/> YES <input type="checkbox"/> NO	<input type="checkbox"/> YES <input type="checkbox"/> NO	
34	<input type="checkbox"/> SPEC. QTY, SIZE, 6000 LB NPT CPLG, FLG TYPE & RATING			
35	<input type="checkbox"/> *QTY, SIZE, 6000 LB NPT CPLG, FLG TYPE & RATING			
36	<input type="checkbox"/> TEMPERATURE CONNECTIONS REQUIRED	<input type="checkbox"/> YES <input type="checkbox"/> NO	<input type="checkbox"/> YES <input type="checkbox"/> NO	
37	<input type="checkbox"/> SPEC. QTY, SIZE, 6000 LB NPT CPLG/FLG TYPE & RATING			
38	<input type="checkbox"/> CYL NOZZLE <input type="checkbox"/> MAIN BODY			
39	<input type="checkbox"/> *QTY, SIZE, 6000 LB NPT CPLG/FLG TYPE & RATING			
40				
41				
42	OTHER DATA AND NOTES			
43	PUMP MFG'S SUPP. OUTLINE OR DRAWING NO.			
44	SUPPRESSOR MFG'S OUTLINE OR DRAWING NO.			
45	NOTES * = AS BUILT			
46				
47				
48				
49				
50				
51				

RECIPROCATING PUMP DATA SHEET
SI UNITS

JOB NO. _____ ITEM NO. _____
PURCH. ORDER NO. _____ DATE _____
INQUIRY NO. _____ BY _____
REVISION _____ DATE _____

1 APPLICABLE TO: PROPOSAL PURCHASE AS BUILT
2 FOR _____ UNIT _____
3 SITE _____ NO. OF PUMPS REQUIRED _____
4 SERVICE _____ SIZE AND TYPE _____
5 MANUFACTURER _____ SERIAL NO. _____

6 NOTE: INDICATES INFORMATION TO BE COMPLETED BY PURCHASER BY MANUFACTURER

7 **GENERAL**

8 NO. MOTOR DRIVEN _____	OTHER DRIVER TYPE _____
9 PUMP ITEM NO'S _____	PUMP ITEM NO'S _____
10 MOTOR ITEM NO'S _____	DRIVER ITEM NO'S _____ GEAR ITEM NO'S _____
11 MOTOR PROVIDED BY _____	DRIVER PROVIDED BY _____ GEAR PROVIDED BY _____
12 MOTOR MOUNTED BY _____	DRIVER MOUNTED BY _____ GEAR MOUNTED BY _____
13 MOTOR DATA SHEET NO. _____	DRIVER DATA SHEET NO. _____ GEAR DATA SHEET NO. _____

14 **OPERATING CONDITIONS**

15 CAPACITY @ PT (m³/h):
16 @ MAXIMUM VISCOSITY _____ @ MINIMUM VISCOSITY _____
17 DISCHARGE PRESSURE (kPa)(BARG):
18 MAXIMUM _____ MINIMUM _____
19 SUCTION PRESSURE (kPa)(BARG):
20 MAXIMUM _____ MINIMUM _____
21 DIFFERENTIAL PRESSURE (kPa)(BAR):
22 MAXIMUM _____ MINIMUM _____
23 NPSH AVAILABLE (m) WITHOUT ACCELERATION HEAD _____
24 ACCELERATION HEAD (APP G) _____ NET _____

25 **PERFORMANCE**

26 RATED CAPACITY (m³/h) _____
27 NPSH REQUIRED (m) _____
28 PISTON SPEED (m/h) _____
29 DISPLACEMENT (m³/h) _____
30 VOLUMETRIC EFFICIENCY (%) _____
31 MECHANICAL EFFICIENCY (%) _____
32 kW @ MAXIMUM VISCOSITY _____
33 kW @ RELIEF VALVE SETTING _____
34 MAXIMUM ALLOWABLE SPEED (RPM) _____
35 MINIMUM ALLOWABLE SPEED (RPM) _____
36 PINION SHAFT (RPM) _____
37 HYDRAULIC kW _____ BRAKE kW _____
38 **FOR DIRECT-ACTING PUMPS:**
39 DRIVE GAS _____
40 GOVERNOR TYPE _____
41 INLET PRESSURE (kPa)(BARG) _____
42 INLET TEMPERATURE (C) _____
43 EXHAUST PRESSURE (kPa)(BARG) _____
44 STALL PRESSURE (kPa)(BARG) _____
45 GAS CONSUMPTION (kg/kW-h) _____

46 **APPLICABLE SPECIFICATIONS**

47 API 674 POSITIVE DISPLACEMENT PUMPS - RECIPROCATING

48 GOVERNING SPECIFICATION (IF DIFFERENT) _____

49 REMARKS: _____

50 _____

51 _____

14 **LIQUID**

TYPE OR NAME OF LIQUID _____
 PUMPING TEMPERATURE (°C): COMPRESSIBILITY % _____
NORMAL _____ MAXIMUM _____ MINIMUM _____
 SPECIFIC GRAVITY _____ MAXIMUM _____ MINIMUM _____
 SPECIFIC HEAT _____ Cp (kJ/kg °C) _____
 VISCOSITY (cp) _____ MINIMUM _____ MAXIMUM _____
 CORROSIVE/EROSIVE AGENTS _____
 CHLORIDE CONCENTRATION (PPM) _____
 H₂S CONCENTRATION (PPM) _____
LIQUID TOXIC FLAMMABLE OTHER _____

25 **SITE AND UTILITY DATA**

LOCATION INDOOR OUTDOOR
 HEATED UNHEATED UNDER ROOF
 ELECTRICAL AREA CLASS _____ GROUP _____ ZONE _____
 WINTERIZATION REQD TROPICALIZATION REQD
SITE DATA
 RANGE OF AMBIENT TEMPS: MIN/MAX _____/_____/____ °C
UNUSUAL CONDITIONS
 DUST FUMES SALT ATMOSPHERE
 OTHER _____
 UTILITY CONDITIONS
ELECTRICITY DRIVERS HEATING CONTROL SHUTDOWN
VOLTAGE _____
HERTZ _____
PHASE _____
COOLING WATER INLET RETURN DESIGN MAX Δ
TEMP °C _____ MAX _____
PRESS. (kPa)(BARG) _____ MIN _____
SOURCE _____
INSTRUMENT AIR _____ MAX _____ MIN _____
PRESSURE (kPa)(BARG) _____

RECIPROCATING PUMP DATA SHEET SI UNITS

PAGE _____ OF _____

JOB NO. _____ ITEM NO. _____

REVISION _____ DATE _____

BY _____

<input type="checkbox"/> CONSTRUCTION										
LIQUID END: (2.7.1.1 THROUGH 2.7.1.4)			NOZZLES		SIZE	ANSI RATING	FACING	LOCATION		
<input type="checkbox"/> SIMPLEX	<input type="checkbox"/> MULTIPLEX	<input type="checkbox"/> PLUNGER	LIQUID SUCTION		_____	_____	_____	_____		
<input type="checkbox"/> DUPLEX	<input type="checkbox"/> NO. OF CYLINDERS	<input type="checkbox"/> PISTON	LIQUID DISCHARGE		_____	_____	_____	_____		
<input type="checkbox"/> SINGLE ACTING	<input type="checkbox"/> HORIZONTAL	<input type="checkbox"/> REMOVABLE LINERS	GAS INLET		_____	_____	_____	_____		
<input type="checkbox"/> DOUBLE ACTING	<input type="checkbox"/> VERTICAL	<input type="checkbox"/> NO LINERS	GAS EXHAUST		_____	_____	_____	_____		
VALVES PER CORNER:			GLAND FLUSH		_____	_____	_____	_____		
	NUMBER	AREA (mm ²)	VELOCITY (m/h)	DRAINS	_____	_____	_____	_____		
<input type="checkbox"/> SUCTION	_____	_____	_____	OTHER	_____	_____	_____	_____		
<input type="checkbox"/> DISCHARGE	_____	_____	_____	OTHER	_____	_____	_____	_____		
VALVE TYPE: <input type="checkbox"/> DISC <input type="checkbox"/> WING <input type="checkbox"/> DOUBLE PORTED <input type="checkbox"/> BALL				OTHER	_____	_____	_____	_____		
<input type="checkbox"/> MATERIALS										
PART	LIQUID END			ASTM NO.		GAS END				
CYLINDER	_____			_____		_____				
LINER	_____			_____		_____				
PISTON OR PLUNGER	_____			_____		_____				
PISTON RINGS	_____			_____		_____				
PISTON ROD	_____			_____		_____				
VALVES/VALVESEATS	_____			_____		_____				
GLAND	_____			_____		_____				
THROAT BUSHING	_____			_____		_____				
PACKING	_____			_____		_____				
LANTERN RING	_____			_____		_____				
BOLTING	_____			_____		_____				
OTHER	_____			_____		_____				
OTHER	_____			_____		_____				
<input type="checkbox"/> LIQUID END LUBRICATION					<input type="checkbox"/> PACKING					
<input type="radio"/> PACKING LUBE	_____				LIQUID END		GAS END		VALVE ROD	
<input type="radio"/> FLUSH SOURCE	_____				NO. OF RINGS		_____		_____	
<input type="checkbox"/> LUBRICATOR MAKE	_____				SIZE OF RINGS		_____		_____	
SIZE	_____				OTHER		_____		_____	
NO. OF FEEDS _____										
<input type="checkbox"/> PRESSURE RATINGS					<input type="checkbox"/> QA INSPECTION AND TEST					
	LIQUID CYLINDER		GAS CYLINDER		<input type="radio"/> COMPLIANCE WITH INSPECTORS CHECK LIST <input type="radio"/> CERTIFICATION OF MATERIALS <input type="radio"/> FINAL ASSEMBLY CLEARANCES <input type="radio"/> SURFACE AND SUBSURFACE EXAMINATIONS <input type="radio"/> RADIOGRAPHY <input type="radio"/> ULTRASONIC <input type="radio"/> MAGNETIC PARTICLE <input type="radio"/> LIQUID PENETRANT <input type="radio"/> CLEANLINESS PRIOR TO FINAL ASSEMBLY <input type="radio"/> HARDNESS OF PARTS, WELDS & HEAT AFFECTED ZONES <input type="radio"/> FURNISH PROCEDURES FOR OPTIONAL TESTS					
MAXIMUM PRESSURE (kPa)(BARG)	_____		_____		TESTS					
MAXIMUM TEMPERATURE (C)	_____		_____		HYDROSTATIC					
HYDROSTATIC TEST PRESS. (kPa)(BARG)	_____		_____		PERFORMANCE					
OTHER	_____		_____		NPSH					
<input type="checkbox"/> DRIVE MECHANISM					OTHER					
<input type="radio"/> DIRECT COUPLED	<input type="radio"/> V-BELT OR COG	<input type="radio"/> GEAR		REQ'D						
<input type="checkbox"/> COUPLING MANUFACTURER _____				W/T						
<input type="radio"/> SOLEPLATES	<input type="radio"/> BASEPLATE	<input type="radio"/> SKID		OBS						
<input type="radio"/> BY PUMP MANUFACTURER	SUITABLE FOR EPOXY GROUT			<input type="radio"/> ● <input type="radio"/> <input type="radio"/>						
<input type="radio"/> EXTENDED FOR _____				<input type="radio"/> ○ <input type="radio"/> <input type="radio"/>						
<input type="radio"/> SUBPLATES BY PUMP MANUFACTURER				<input type="radio"/> ○ <input type="radio"/> <input type="radio"/>						
<input type="radio"/> DRAIN-RIM	<input type="radio"/> DRAIN-PAN				<input type="radio"/> ○ <input type="radio"/> <input type="radio"/>					
<input type="radio"/> LEVELING PADS	<input type="radio"/> SUITABLE FOR COLUMN MOUNTING			<input type="radio"/> ○ <input type="radio"/> <input type="radio"/>						
REMARKS _____										

RECIPROCATING PUMP DATA SHEET

SI UNITS

PAGE _____ OF _____

JOB NO. _____ ITEM NO. _____

REVISION _____ DATE _____

BY _____

<p>1 <input type="checkbox"/> POWER FRAME</p> <p>2 MAXIMUM FRAME RATING:</p> <p>3 _____ kW @ _____ rpm</p> <p>4 MAXIMUM PRESSURE RATING (kPa) (BARG) _____</p> <p>5 CRANKSHAFT MATERIAL _____</p> <p>6 NO. OF MAIN BEARINGS _____</p> <p>7 TYPE OF MAIN BEARINGS _____</p> <p>8 INTERNAL GEARS <input type="checkbox"/> YES <input type="checkbox"/> NO</p> <p>9 GEAR RATIO _____</p> <p>10 GEAR SERVICE FACTOR _____</p> <p>11 POWER END LUBRICATION:</p> <p>12 TYPE <input type="radio"/> SPLASH <input type="radio"/> POSITIVE PRESSURE <input type="radio"/> GRAVITY</p> <p>13 OIL PUMP: _____</p> <p>14 MAIN _____</p> <p>15 <input type="radio"/> AUXILIARY _____</p> <p>16 <input type="radio"/> DRIVEN BY _____</p> <p>17 OIL FILTER:</p> <p>18 TYPE _____ <input type="radio"/> MAKE _____</p> <p>19 <input type="checkbox"/> FILTRATION SIZE _____ <input type="radio"/> MODEL _____</p> <p>20 <input type="radio"/> OIL COOLER</p> <p>21 TYPE _____</p> <p>22 SIZE _____</p> <p>23 DRIVERS</p> <p>24 <input type="radio"/> MOTOR</p> <p>25 <input type="checkbox"/> MANUFACTURER _____</p> <p>26 <input type="checkbox"/> TYPE _____</p> <p>27 <input type="checkbox"/> FRAME NO. _____</p> <p>28 <input type="radio"/> CONSTANT SPEED _____</p> <p>29 <input type="radio"/> VARIABLE SPEED _____</p> <p>30 <input type="checkbox"/> kW _____ RPM _____</p> <p>31 <input type="radio"/> VOLTS _____ PHASE _____</p> <p>32 <input type="radio"/> HERTZ _____ SERVICE FACTOR _____</p> <p>33 <input type="radio"/> ENCLOSURE _____</p> <p>34 <input type="radio"/> _____</p> <p>35 <input type="radio"/> STEAM TURBINE</p> <p>36 <input type="radio"/> OTHER (SEE SEPARATE DATA SHEETS) _____</p> <p>37 GEAR REDUCER</p> <p>38 <input type="radio"/> REQUIRED _____</p> <p>39 <input type="checkbox"/> MANUFACTURER _____</p> <p>40 <input type="checkbox"/> MODEL _____</p> <p>41 <input type="checkbox"/> TYPE _____</p> <p>42 <input type="checkbox"/> SERVICE FACTOR _____</p> <p>43 <input type="checkbox"/> RATING _____</p> <p>44 V-BELT OR CHAIN DRIVE</p> <p>45 <input type="radio"/> REQUIRED _____</p> <p>46 <input type="checkbox"/> NO. OF BELTS _____</p> <p>47 <input type="checkbox"/> SIZE OF BELTS _____</p> <p>48 <input type="checkbox"/> CHAIN DETAILS _____</p> <p>49 <input type="radio"/> TOTALLY ENCLOSED GUARD _____</p> <p>50 <input type="radio"/> SLIDE RAILS FOR ADJUSTMENT _____</p> <p>51</p>	<p style="text-align: center;">CONTROLS</p> <p>TYPE:</p> <p><input type="radio"/> MANUAL <input type="radio"/> REMOTE <input type="radio"/> PNEUMATIC</p> <p><input type="radio"/> AUTOMATIC <input type="radio"/> LOCAL <input type="radio"/> ELECTRONIC</p> <p>CAPACITY CONTROL:</p> <p><input type="radio"/> FLOW BYPASS <input type="radio"/> VARIABLE SPEED <input type="radio"/> COMBINATION</p> <p style="padding-left: 40px;">ONLY ONLY</p> <p><input type="radio"/> VENDOR FURNISHES CS GOVERNOR & VALVE</p> <p><input type="radio"/> VENDOR TO FURNISH CONTROL PANEL</p> <p style="padding-left: 40px;"><input type="radio"/> FREESTANDING <input type="radio"/> ON UNIT <input type="radio"/> OTHER _____</p> <p><input type="radio"/> TACHOMETER REQUIRED TYPE _____</p> <p style="text-align: center;">OTHER PURCHASE REQUIREMENTS</p> <p>NAMEPLATE UNITS <input type="radio"/> CUSTOMARY <input type="radio"/> SI</p> <p><input type="radio"/> VENDOR FURNISHED PROCESS PIPING _____</p> <p><input type="radio"/> VENDOR REVIEW PIPING DRAWINGS</p> <p><input type="radio"/> VENDOR FURNISHED PULSATION SUPPRESSION DEVICES</p> <p><input type="radio"/> VENDOR FURNISHED RELIEF VALVE</p> <p><input type="radio"/> INTERNAL <input type="radio"/> EXTERNAL</p> <p><input checked="" type="checkbox"/> RELIEF VALVE SETTING (PSIG)</p> <p><input type="radio"/> LIQUID-FILLED PRESSURE GAUGES REQUIRED</p> <p><input type="radio"/> TECHNICAL DATA MANUAL REQUIRED</p> <p><input type="radio"/> MAXIMUM SOUND PRESSURE LEVEL _____ dBA</p> <p style="padding-left: 40px;">@ _____ m</p> <p><input type="radio"/> OVERSIZE NOZZLE MATING PARTS BY VENDOR</p> <p><input type="radio"/> QUENCH-TYPE GLANDS REQUIRED</p> <p><input type="radio"/> PROVIDE PACKING COLLECTION CHAMBER</p> <p><input type="radio"/> PROVIDE LANTERN RING PURGE</p> <p style="padding-left: 40px;"><input type="checkbox"/> SIZE _____</p> <p><input type="radio"/> OIL HEATER CONNECTION REQUIRED</p> <p>DISTANCE PIECE COVERS</p> <p style="padding-left: 40px;"><input type="radio"/> SAFETY <input type="radio"/> LOUVERED <input type="radio"/> SOLID</p> <p style="padding-left: 80px;">GUARDS WEATHER COVERS</p> <p style="padding-left: 80px;">COVERS</p> <p>ADDITIONAL OIL SYSTEM ITEMS</p> <p style="padding-left: 40px;"><input type="radio"/> FLOW <input type="radio"/> PRESSURE <input type="radio"/> TEMPERATURE</p> <p style="padding-left: 80px;">INDICATOR GAUGES GAUGES</p> <p style="padding-left: 40px;"><input type="radio"/> STRAINER <input type="radio"/> OTHER _____</p> <p>OIL HEATER REQUIRED</p> <p style="padding-left: 40px;"><input type="radio"/> STEAM <input type="radio"/> ELECTRIC</p> <p><input type="radio"/> MECHANICAL LUBRICATOR REQUIRED</p> <p>MINIMUM DESIGN METAL TEMPERATURE °C _____</p> <p>GEARS COMPLY WITH <input type="radio"/> API 613 <input type="radio"/> API 677</p> <p><input type="radio"/> API 671 COUPLINGS AND GAUGES REQUIRED</p> <p style="text-align: center;">PREPARATION FOR SHIPMENT</p> <p><input type="radio"/> DOMESTIC <input type="radio"/> EXPORT <input type="radio"/> EXPORT BOXING</p> <p><input type="radio"/> OUTDOOR STORAGE MORE THAN 6 MONTHS</p> <p style="text-align: center;">WEIGHTS (kg)</p> <p><input type="checkbox"/> PUMP _____ <input type="checkbox"/> BASE _____ <input type="checkbox"/> GEAR _____ <input type="checkbox"/> DRIVER _____</p>
---	--

RECIPROCATING PUMP DATA SHEET

SI UNITS

PAGE _____ OF _____
 JOB NO. _____ ITEM NO. _____
 REVISION _____ DATE _____
 BY _____

1	PULSATION SUPPRESSION DEVICES FOR RECIPROCATING PUMPS (CONTD)		SERVICE _____
2	THESE SHEETS TO BE FILLED OUT FOR EACH SERVICE AND/OR STAGE		STAGE NO. _____
3	APPLICABLE TO: <input type="radio"/> PROPOSAL <input type="radio"/> PURCHASE <input type="radio"/> AS BUILT		
4	FOR/USER _____		
5	SITE/LOCATION _____	AMBIENT TEMPERATURE MIN/MAX _____ / _____ °C	
6	PUMP SERVICE _____	NUMBER OF PUMPS _____	
7	PUMP MFG. _____	MODEL/TYPE _____	
8	SUPPRESSOR MFG. _____		
9	NOTE: <input type="radio"/> Data Completed Purch. <input type="checkbox"/> By Pump/Supp. Mfg. w/Proposal <input type="checkbox"/> By Mfg(s) after order <input type="checkbox"/> By Mfg(s)/Purchaser as Applicable		
10	GENERAL INFORMATION APPLICABLE TO ALL SUPPRESSORS		
11			
12	TOTAL NUMBER OF SERVICES AND/OR STAGES _____		
13	<input type="radio"/> ASME CODE STAMP <input type="radio"/> STATE/COUNTRY/PROVINCE OF _____ CODE REGULATIONS APPLY		
14	<input type="radio"/> OTHER APPLICABLE PRESSURE VESSEL SPEC. OR CODE _____		
15	RADIOGRAPHY (X-RAY OF WELDS): <input type="radio"/> NONE <input type="radio"/> SPOT <input type="radio"/> 100% <input type="radio"/> IMPACT TEST <input type="radio"/> SPECIAL WELDING REQUIREMENTS		
16	<input type="radio"/> SHOP INSPECTION <input type="radio"/> OUTDOOR STORAGE OVER 6 MONTHS <input type="radio"/> SPECIAL PAINT SPEC _____		
17			
18	DESIGN APPROACH: <input type="radio"/> 1 W/SIMPLIFIED MANUAL ANALYSIS OF PIPING SYSTEM		
19	<input type="radio"/> 2. ACOUSTIC SIMULATION STUDY		
20	STUDY TO BE WITNESSED: <input type="radio"/> YES <input type="radio"/> NO		
21	HYDROTEST <input type="radio"/> WITNESS <input type="radio"/> OBSERVE		
22	OPERATING AND SUPPRESSOR DESIGN DATA		
23	<input type="checkbox"/> PUMP DATA, THIS SERVICE OR STAGE ONLY NOTES: _____ _____ _____	NUMBER OF CYL. _____ INTERNAL PASSAGES _____	
24		BORE DIA _____ mm STROKE _____ mm RPM _____	
25		PUMP VALVE DATA	
26	TYPE _____ LIFT _____ mm WEIGHT _____ g		
27	SPRING PRELOAD _____ N SPRING RATE _____ LIFT AREA _____		
28	FULL PROJECTED AREA _____ EFF. FULL LIFT AREA _____		
29			
30	LIQUID HANDLED-SEE DATA SHT PG. 1 _____ _____	NORMAL OPERATING _____	
31		<input type="radio"/> CORR. PRESENT (DESCRIBE) _____	
32		SPECIFIC GRAVITY _____	
33	COMPRESSIBILITY % _____		
34	<input type="radio"/> OPERATION IN PARALLEL W/ _____		
35	<input type="checkbox"/> PUMP MANUFACTURER'S RATED CAPACITY	m ³ /h _____	
36	<input type="checkbox"/> LINE SIDE OPERATING PRESSURE	INLET _____ (kPa)(BARG)	DISCHARGE _____ (kPa) (BARG)
37	<input type="checkbox"/> OPERATING TEMP WITHIN SUPPRESSORS	INLET _____ °C	<input type="checkbox"/> DISCHARGE _____ °C
38	<input type="checkbox"/> ALLOWABLE PRESSURE DROP THROUGH SUPPRESSORS	ΔP _____ (kPa) (BAR) _____ %	ΔP _____ (kPa) (BARG) _____ %
39	<input type="radio"/> COMBINATION INLET SUPP SEPARATOR/INTERNAL <input type="checkbox"/> NO. (QTY) OF INLET & DISCH. SUPP. PER STAGE <input type="radio"/> ALLOWABLE PEAK-PEAK PULSE @ LINE SIDE NOZZLE <input type="radio"/> ALLOWABLE PEAK-PEAK PULSE @ CYL FLANGE NOZZLE <input type="radio"/> MIN. REQ'D WORKING PRESSURE & TEMPERATURE NOTE: After design, the actual Mawp & temp are to be determined based on the weakest component and stamped on the vessel. The actual Mawp is to be shown on pg. 5 line 11 and on the U1A Forms.	INLET SUPPRESSOR	
40		<input type="radio"/> YES <input type="radio"/> NO / <input type="radio"/> YES <input type="radio"/> NO	
41		DISCHARGE SUPPRESSOR	
42		<input type="radio"/> YES <input type="radio"/> NO / <input type="radio"/> YES <input type="radio"/> NO	
43		(kPa) (BARG) %	
44	(kPa) (BARG) %		
45	(kPa) (BARG) @ _____ °C		
46	(kPa) (BARG) @ _____ °C		
47			
48			
49			
50			
51			

RECIPROCATING PUMP DATA SHEET

SI UNITS

PAGE _____ OF _____
 JOB NO. _____ ITEM NO. _____
 REVISION _____ DATE _____
 BY _____

1	PULSATION SUPPRESSION DEVICES FOR RECIPROCATING PUMPS (CONTD)	SERVICE _____	
2	THESE SHEETS TO BE FILLED OUT FOR EACH SERVICE AND/OR STAGE	STAGE NO. _____	
3	CONSTRUCTION REQUIREMENTS & DATA	INLET SUPPRESSOR	DISCHARGE SUPPRESSOR
4	<input type="checkbox"/> BASIC MATERIAL REQUIRED, CS, SS, ETC.		
5	<input type="checkbox"/> ACT. MAT., ASTM OR SA DESIGNATION SHELL / HEAD	/	/
6	<input type="checkbox"/> SPECIAL HARDNESS LIMITATIONS R _c <input type="checkbox"/> YES <input type="checkbox"/> NO	SHELL & HEADS	SHELL & HEADS
7	<input checked="" type="checkbox"/> CORROSION ALLOW. (mm) <input type="checkbox"/> REQUIRED	WELDS	WELDS
8	<input type="checkbox"/> WALL THICKNESS, (mm) SHELL/HEAD	mm	mm
9	<input type="checkbox"/> NOM. SHELL DIA x OVERALL LGTH. mm/VOL. m ³	mm / mm	mm / mm
10	<input type="checkbox"/> PIPE OR ROLLED PLATE CONSTRUCTION	x mm / m ³	x mm / m ³
11	<input type="checkbox"/> ACT MAX ALLOW. WORKING PRESS AND TEMPERATURE	<input type="checkbox"/> PIPE <input type="checkbox"/> ROLLED PLATE	<input type="checkbox"/> PIPE <input type="checkbox"/> ROLLED PLATE
12	<input type="checkbox"/> MAX EXPECTED PRESSURE DROP ΔP, (kPa)(BAR) % LINE PRESS	(kPa) (BARG) @ °C	(kPa) (BARG) @ °C
13	<input type="checkbox"/> WEIGHT, kg EACH	ΔP (kPa) (BAR) / %	ΔP (kPa) (BAR) / %
14	<input type="checkbox"/> INSUL NUTS & ALLOW. FOR INSULATION REQUIRED	kg	kg
15	<input type="checkbox"/> EXPECTED P-P PULSE @ LINE SIDE CYL FLG, % LINE PRESS	<input type="checkbox"/> YES <input type="checkbox"/> NO	<input type="checkbox"/> YES <input type="checkbox"/> NO
16	BASED ON FINAL SUPPRESSOR DESIGN	%/ %	%/ %
17			
18	<input checked="" type="checkbox"/> SUPPORTS, TYPE/QUANTITY		
19	CONNECTION REQUIREMENTS & DATA		
20	<input type="checkbox"/> LINE SIDE FLANGE, SIZE RATING/FACING/TYP		
21	<input type="checkbox"/> PUMP FLANGE(S), QTY: SIZE RATING/FACING/TYP		
22	<input type="checkbox"/> FLANGE FINISH, <input type="checkbox"/> SPECIAL (SPECIFY)		
23	<input type="checkbox"/> PER ASME 16.5		
24	<input type="checkbox"/> INSPECTION OPENINGS REQUIRED	<input type="checkbox"/> YES <input type="checkbox"/> NO <input type="checkbox"/> BLINDED	<input type="checkbox"/> YES <input type="checkbox"/> NO <input type="checkbox"/> BLINDED
25	<input type="checkbox"/> SPEC. QTY, SIZE, 6000 LB NPT CPLG, FLG TYPE & RATING		
26	<input type="checkbox"/> *QTY, SIZE, 6000 LB NPT CPLG, FLG TYPE & RATING		
27	<input type="checkbox"/> VENT CONNECTIONS REQUIRED	<input type="checkbox"/> YES <input type="checkbox"/> NO	<input type="checkbox"/> YES <input type="checkbox"/> NO
28	<input type="checkbox"/> SPEC. QTY, SIZE, 6000 LB NPT CPLG, FLG TYPE & RATING		
29	<input type="checkbox"/> *QTY, SIZE, 6000 LB NPT CPLG, FLG TYPE & RATING		
30	<input type="checkbox"/> DRAIN CONNECTIONS REQUIRED	<input type="checkbox"/> YES <input type="checkbox"/> NO	<input type="checkbox"/> YES <input type="checkbox"/> NO
31	<input type="checkbox"/> SPEC. QTY, SIZE, 6000 LB NPT CPLG, FLG TYPE & RATING		
32	<input type="checkbox"/> *QTY, SIZE, 6000 LB NPT CPLG, FLG TYPE & RATING		
33	<input type="checkbox"/> PRESSURE CONNECTIONS REQUIRED	<input type="checkbox"/> YES <input type="checkbox"/> NO	<input type="checkbox"/> YES <input type="checkbox"/> NO
34	<input type="checkbox"/> SPEC. QTY, SIZE, 6000 LB NPT CPLG, FLG TYPE & RATING		
35	<input type="checkbox"/> *QTY, SIZE, 6000 LB NPT CPLG, FLG TYPE & RATING		
36	<input type="checkbox"/> TEMPERATURE CONNECTIONS REQUIRED	<input type="checkbox"/> YES <input type="checkbox"/> NO	<input type="checkbox"/> YES <input type="checkbox"/> NO
37	<input type="checkbox"/> SPEC. QTY, SIZE, 6000 LB NPT CPLG/FLG TYPE & RATING		
38	<input type="checkbox"/> CYL NOZZLE <input type="checkbox"/> MAIN BODY		
39	<input type="checkbox"/> *QTY, SIZE, 6000 LB NPT CPLG/FLG TYPE & RATING		
40			
41			
42	OTHER DATA AND NOTES		
43	PUMP MFG'S SUPP. OUTLINE OR DRAWING NO.		
44	SUPPRESSOR MFG'S OUTLINE OR DRAWING NO.		
45	NOTES * - AS BUILT		
46			
47			
48			
49			
50			
51			

**APPENDIX B—MATERIALS AND MATERIAL SPECIFICATIONS
FOR MAJOR COMPONENT PARTS**

Table B-1—Materials for Reciprocating Pump Liquid End Parts

Part	Material Class and Material Class Abbreviations ^a			
	I-1	I-2	S-1	S-2
	CI	CI	STL	STL
	CI	BRZ	CI	HI ALLOY
Pressure-Retaining Parts				
Cylinder	Cast iron	Cast iron	Carbon steel	Carbon steel
Cylinder head, valve cover	Cast iron or carbon steel	Cast iron or carbon steel	Carbon steel	Carbon steel
Stuffing box carbon steel	Cast iron or carbon steel	Cast iron or	Carbon steel	Carbon steel
Gland	Cast iron or carbon steel	Cast iron or carbon steel	Carbon steel	Carbon steel
Bolting	Carbon steel	Carbon steel	AISI 4140 steel	AISI 4140 steel
Non-Pressure-Retaining Parts				
Lantern ring, throat bushing, packing follower	Cast iron, 12% chrome, or any stainless steel	Cast iron or bronze 12% chrome, or any stainless steel	Cast iron, or any stainless steel	12% Chrome
Valve and seat	Stainless steel	Bronze stainless steel	Carbon steel or any any stainless steel	12% Chrome or
Valve spring	Stainless steel	Bronze or stainless steel	Stainless steel stainless steel	Inconel or
Piston ^b	Cast iron	Cast iron	Cast iron	Ni-resist
Piston rod ^b	12% Chrome	12% Chrome	12% Chrome	12% Chrome
Piston ring ^b	Cast iron or nonmetallic	Nonmetallic	Cast iron or nonmetallic	Special cast iron or Ni-resist
Piston ring expander ^b	Cast iron or stainless steel	Stainless steel	Cast iron or stainless steel	Stainless steel
Plunger (power pumps) ^b	12% Chrome, hard surfaced	12% Chrome, hard surfaced	12% Chrome, hard surfaced	12% Chrome, hard surfaced
Plunger (direct-acting pumps) ^b	12% Chrome, hardened	12% Chrome, hardened	12% Chrome, hardened	12% Chrome, hardened
Cylinder liner ^b	Cast iron	Bronze	Cast iron	Ni-resist or 12% chrome

Note: This table is to be used as a guide.

^aThe abbreviation above the diagonal line indicates cylinder material; the abbreviation below the diagonal line indicates fitting material. Abbreviations are as follows: CI = cast iron, BRZ = bronze, STL = steel, HI ALLOY = high-temperature alloy.

^bApplies where applicable.

Table B-2—Materials for Direct-Acting Reciprocating Pump Gas End Parts

Part	Material Class and Material Class Abbreviations ^a							
	I-1		I-2		S-1		S-2	
	CI	CI	CI	BRZ	STL	CI	STL	HI ALLOY
Pressure-Retaining Parts								
Cylinder	Cast iron		High-temperature cast iron		Carbon steel		Carbon steel	
Head, chest, cover	Cast iron or steel		High-temperature cast iron or steel		Carbon steel		Carbon steel	
Stuffing box	Cast iron or steel		High-temperature cast iron or steel		Carbon steel		Carbon steel	
Gland	Cast iron or steel		High-temperature cast iron or steel		Carbon steel		Carbon steel	
Head, chest, box, and gland bolting	AISI 4140 steel		AISI 4140 steel		AISI 4140 steel		AISI 4140 steel	
Non-Pressure-Retaining Parts								
Cylinder liner	None		None		Cast iron		High-temperature cast iron	
Box bushing ^b	Cast iron		Cast iron		Cast iron		Cast iron	
Piston	Cast iron		Cast iron		Cast iron		High-temperature cast iron	
Piston rod	12% Chrome		12% Chrome, hardened		12% Chrome		12% Chrome, hardened	
Piston ring	Cast iron		Cast iron		Cast iron		Special cast iron	
Main valve	Cast iron		Cast iron		Cast iron		High-temperature cast iron	
Valve rings ^b	Cast iron		Cast iron		Cast iron		Special cast iron	
Auxiliary valve ^b	Cast iron		Cast iron		Cast iron		High-temperature cast iron	
Valve rod	12% Chrome		12% Chrome, hardened		12% Chrome		12% Chrome, hardened	

Note: This table is to be used as a guide.

^aThe abbreviation above the diagonal line indicates cylinder material; the abbreviation below the diagonal line indicates fitting material. Abbreviations are as follows: CI = cast iron, STL = steel, HI ALLOY = high-temperature alloy.

^bApplies where applicable.

Table B-3—Material Specifications for Reciprocating Pump Parts

Material	Castings	Forgings	Bar Stock	Bolts and Suds
Cast iron	ASTM A 48 or A 278	---	—	
Nodular iron	ASTM A 395 or A 536	---	—	
High-temperature cast iron	ASTM A 278, Class 40 or 60, stress-relief, annealed	---	—	
Carbon steel	ASTM A 216, Grade WCA or WCB, or ASTM A 352	ASTM A 105 or A 576	ASTM A 108 or A 575	—
5% Chrome steel	ASTM A 217, Grade C5	ASTM A 182, Grade F5	---	
12% Chrome steel	ASTM A 296, Grade CA6NM or CA15	ASTM A 182, Grade F6	ASTM A 276, Type 410, or ASTM A 582, Type 416	ASTM A 193, Grade B6
18-8 Stainless steel	ASTM A 296, Grade CF20	ASTM A 182, Grade F304	ASTM A 276, Type 304	ASTM A 193, Grade B8
316 Stainless steel	ASTM A 296, Grade CF8M	ASTM A 182, Grade F316	ASTM A 276, Type 316	ASTM A 193, Grade B8M
AISI 4140 steel	—	—	ASTM A 322, Grade 4140	ASTM A 193, Grade B7
Bronze	ASTM B 584	—	ASTM B 139	ASTM B 124
Material	Typical Description			
Ni-resist	Type 1, 2, or 3 as recommended by International Nickel Co. for service conditions			
Hardenable stainless steel	ARMCO 17-7 PH, ARMCO 17-4 PH, U.S. Steel Stainless W, Allegheny Ludlum AM 350 and AM 355, Nitronic 50 or 60			
Colmonoy	Sprayed or fused deposit of 0.5 millimeters (0.020 inch) or gas weld deposit of 0.8 millimeters (1/32 inch) minimum thickness of Wall-Colmonoy AWS, Class R, Ni-Cr-C Meteo 16c			

Note: This table is to be used as a guide.

APPENDIX C—INSPECTOR'S CHECKLIST

INSPECTOR'S CHECKLIST

No.	Item	API Standard 674 Reference	Date Inspected	Inspected By	Status
1.	Cylinder Liners	2.6.1			
2.	Valve Seats	2.6.3			
3.	Material certification	2.10.1.2 4.2.1.1.a			
4.	Nondestructive examination (components)	2.10.1.3			
5.	Welding operators and procedures qualified	2.10.4.1 2.10.4.3			
6.	Rotation arrow*	2.11.2			
7.	Equipment nameplate data	2.11.3			
8.	Overall dimensions and connection locations*				
9.	Nozzle flange dimensions*				
10.	Anchor bolt layout and size*				
11.	Shaft and keyway dimensions*				
12.	Mounting plate precoat for epoxy grout	3.3.1.2.6			
13.	Equipment feet pilot holes	3.3.1.2.12			
14.	Relief valve characteristics	3.4.4.7			
15.	Piping inspection	3.5.1			
16.	Pulsation support devices	3.6			
17.	Special tools*	3.7			
18.	Certified performance data	4.2.2.1.c			
19.	Maintenance and clearance data	4.2.1.1.d			
20.	Components inspected for cleanliness (list each)	4.2.3.3			
21.	Hardness testing	4.2.3.4			
22.	Hydrostatic tests	4.3.2			
23.	Performance test, direct acting pump	4.3.3			
24.	Performance test, power pump	4.3.4			
25.	NPSH test	4.3.6			
26.	Preparation for shipment	4.4			
27.	Painting	4.4.3.1			
28.	Shipping documents and tags	4.4.3.8			
29.	Bearing assembly protection	4.4.5			

* Check against certified dimensional outline drawing.

**APPENDIX D—API 674 VENDOR DRAWINGS AND DATA
REQUIREMENTS**

API 674 VENDOR DRAWING AND DATA REQUIREMENTS

FOR _____ JOB NO. _____ ITEM NO. _____
SITE _____ PURCHASE ORDER NO. _____ DATE _____
SERVICE _____ REQUISITION NO. _____ DATE _____
INQUIRY NO. _____ DATE _____
PAGE 1 OF 2 BY _____
REVISION _____ UNIT _____
NO. REQUIRED _____

Proposal ^a	Bidder shall furnish _____ copies of data for all items indicated by an X.
Review ^b	Vendor shall furnish _____ copies and _____ transparencies of drawings and data indicated.
Final ^c	Vendor shall furnish _____ copies and _____ transparencies of drawings and data indicated. Vendor shall furnish _____ operating and maintenance manuals.
DISTRIBUTION RECORD	
Final—Received from vendor _____	
Final—Due from vendor ^c _____	
Review—Returned to vendor _____	
Review—Received from vendor _____	
Review—Due from vendor ^c _____	
DESCRIPTION	
	1. Certified dimensional outline drawing and list of connections.
	2. Cross-sectional drawing and bill of materials.
	3. Thrust-bearing assembly drawing and bill of materials.
	4. Journal-bearing assembly drawing and bill of materials.
	5. Lube-oil schematics and bill of materials.
	6. Lube-oil assembly and arrangement drawings.
	7. Electrical and instrumentation schematics and bills of materials.
	8. Electrical and instrumentation arrangement drawings and lists of connections.
	9. Tabulation of utility requirements.
	10. Curve showing output-power shaft speed versus torque.
	11. Allowable flange loadings.
	12. Coupling alignment diagram.
	13. Welding procedures.
	14. Certified hydrostatic test logs.
	15. Mechanical running test logs.
	16. Performance test logs.
	17. Nondestructive test procedures.
	18. Procedures for special and optional tests (see 4.3.6).
	19. Certified mill test reports.
	20. As-built data sheets.
	21. As-built dimensions and data.
	22. Installation manual.
	23. Operating and maintenance manuals.
	24. Spare-parts recommendations.
	25. Engineering, fabrication, and delivery schedule (progress reports).
	26. List of drawings.
	27. Shipping list.
	28. List of special tools furnished for maintenance.
	29. Technical data manual.

^aProposal drawings and data do not have to be certified or as built. Typical data shall be clearly identified as such.
^bPurchaser will indicate in this column the time frame for submission of materials using the nomenclature given at the end of this form.
^cBidder shall complete these two columns to reflect his actual distribution schedule and include this form with his proposal.

DESCRIPTION

1. Certified dimensional outline drawing and list of connections, including the following:
 - a. Size, rating, and location of all customer connections.
 - b. Approximate overall handling weights.
 - c. Overall dimensions.
 - d. Shaft centerline height.
 - e. Dimensions of baseplates (if furnished), complete with diameter, number, and locations of bolt holes and thickness of the metal through which the bolts must pass; centers of gravity; and details for foundation design.
2. Cross-sectional drawing and bill of materials, including journal-bearing clearances and tolerances.
3. Thrust-bearing assembly drawing and bill of materials.
4. Journal-bearing assembly drawings and bill of materials.
5. Lube-oil schematics and bill of materials, including the following:
 - a. Steady-state and transient oil flows and pressures at each use point.
 - b. Control, alarm, and trip settings (pressures and recommended temperatures).
 - c. Heat loads at each use point at maximum load.
 - d. Utility requirements, including electricity, water, and air.
 - e. Pipe and valve sizes.
 - f. Instrumentation, safety devices, and control schemes.
6. Lube-oil system assembly and arrangement drawings, including size, rating, and location of all customer connections.
7. Electrical and instrumentation schematics and bills of materials for all systems. The schematics shall show all alarm and shutdown limits (set points).
8. Electrical and instrumentation arrangement drawings and list of connections.
9. Tabulation of utility requirements (may be on as-built purchaser data sheets).
10. Curve showing output-power shaft speed versus torque (including starter if applicable; 5.2.4).
11. Allowable flange loadings for all customer connections, including anticipated thermal movements referenced to a defined point.
12. Coupling alignment diagram, including recommended coupling limits during operation. Note all shaft-end position changes and support growth from a reference ambient temperature of 15°C (59°F) or another temperature specified by the purchaser. Include the recommended alignment method and cold setting targets.
13. Welding procedures for fabrication and repair (2.10.1.11, 2.10.2.3.1, 2.10.4.1, 2.10.4.3, 2.10.4.5.4, 3.5.1.12, and 4.2.2.1).
14. Certified hydrostatic test logs.
15. Mechanical running test logs, including but not limited to the following:
 - a. Oil flows, pressures, and temperatures.
 - b. Vibration, including an x-y plot of amplitude and phase angle versus revolutions per minute during start-up and coast-down.
 - c. Bearing metal temperatures.
 - d. When specified, tape recordings of real-time vibration data.
16. Performance test logs.
17. Nondestructive test procedures as itemized on the purchase order data sheets or the Vendor Drawing and Data Requirements form.
18. Procedures for any special or optional tests.
19. Certified mill test reports of items as agreed upon in the precommitment or preinspection meetings.
20. As-built data sheets.
21. As-built dimensions (including nominal dimensions with design tolerances) and data for the following listed parts:
 - a. Shaft or sleeve diameters at
 1. Thrust collar (for separate collars).
 2. Each journal bearing.
 - b. Thrust-collar bore (for separate collars).
 - c. Each journal-bearing inside diameter.
 - d. Thrust-bearing concentricity (axial runout).
 - e. Metallurgy and heat treatment for
 1. Shaft.
 2. Thrust collar.
22. Installation manual describing the following (see 5.3.6.2):
 - a. Storage procedures.
 - b. Foundation plan.
 - c. Grouting details.
 - d. Setting equipment, rigging procedures, component weights, and lifting diagrams.
 - e. Coupling alignment diagram (Item 12 of the VDDR).
 - f. Piping recommendations, including allowable flange loads.
 - g. Composite outline drawings for the driver/driven-equipment train, including anchor-bolt locations.
 - h. Dismantling clearances.
23. Operating and maintenance manuals describing the following:
 - a. Start-up.
 - b. Normal shutdown.
 - c. Emergency shutdown.
 - d. Lube-oil recommendations.
 - e. Routine operational procedures, including recommended inspection schedules and procedures.
 - f. Instructions for
 1. Disassembly and reassembly of journal bearings (for tilting-pad bearings, the instructions shall include "go/no-go" dimensions with tolerances for three-step

- plug gauges).
- 2. Disassembly and reassembly of thrust bearing.
- 3. Disassembly and reassembly of thrust collar.
- g. Performance data including curve showing certified shaft speed versus flow.
- h. As-built data, including
 - 1. As-built data sheets.
 - 2. As-built dimensions or data, including assembly clearances.
 - 3. Hydrostatic test logs, per Item 14 on the VDDR form.
 - 4. Mechanical running test logs, per Item 15 on the VDDR form.
- i. Drawings and data, including
 - 1. Certified dimensional outline drawing and list of connections.
 - 2. Cross-sectional drawing and bill of materials.
 - 3. Thrust-bearing assembly drawing and bill of materials.
 - 4. Journal-bearing assembly drawing and list of connections.
 - 5. Lube-oil schematics and bill of materials.
 - 6. Lube-oil assembly drawing and list of connections.
 - 7. Lube-oil component drawings and data.
 - 8. Electrical and instrumentation schematics and bills of materials.
 - 9. Electrical and instrumentation arrangement drawings and list of connections.
- 24. Spare parts list with stocking level recommendations, in accordance with 5.3.5.
- 25. Progress reports and delivery schedule, including vendor buy-outs and milestones.
- 26. List of drawings, including latest revision numbers and dates.
- 27. Shipping list, including all major components that will ship separately.
- 28. List of special tools furnished for maintenance (3.7).
- 29. Technical data manual, including the following:
 - a. As-built purchaser data sheets, per Item 20 on the VDDR form.
 - b. Certified performance curves, per Items 10 on the VDDR form.
 - c. Drawings, in accordance with 5.3.2.
 - d. As-built assembly clearances.
 - e. Spare parts list, in accordance with 5.3.5.
 - f. Utility data, per Item 9 on the VDDR form.
 - g. Reports, per Items 12, 15, and 16 on the VDDR form.

APPENDIX E—PULSATION CONTROL TECHNIQUES

The following procedures are the minimum required to meet the requirements of 3.6.2 Pulsation Design Approaches.

E.1 Definition of Design Studies

The definition of design studies includes the following:

- a. Design Approach 1: Item E.1.1
- b. Design Approach 2: Items E.1.2 and E.1.3
- c. Optional: Items E.1.4 and E.1.5

E.1.1 ANALYTICAL STUDY

E.1.1.1 The analytical study includes the design of a pump pulsation suppression device using proprietary and/or empirical analytical techniques (acoustical simulation is not required) to meet pulsation levels specified in 3.6.2.2. Note that without an acoustical simulation, it is not possible to know whether or not the specified levels will be met.

E.1.1.2 The analytical study also includes a simplified analysis of the purchaser's piping system to determine critical piping lengths that may be in resonance with acoustical excitation frequencies.

E.1.2 ACOUSTICAL ANALYSIS (ACOUSTICAL SIMULATION STUDY)

The acoustical analysis consists of using modeling techniques which account for the acoustical interaction between the pump and piping. The modeling method must account for the dynamic interaction of the flow through the valves and the resulting dynamic pressure variation in the pump passages and piping. Variations in specified operating conditions shall be analyzed by extending the applicable parameters of the analysis above and below the specified operating conditions. This is normally accomplished by simulating speeds above and below the specified speed(s). The piping system must be modeled to a point where piping changes will have insignificant effects on the parts of the system under study (usually a large vessel upstream and downstream of the units to be studied). The pulsation analysis study must produce the following information:

E.1.2.1. Prediction of Peak-to-Peak Pulsation Levels

Operating conditions and pump pressure steps are chosen to yield the highest expected pulsation amplitudes throughout the piping system. Pulsation amplitudes are then compared to the levels identified in 3.6.2.2.

E.1.2.2. Calculation of Pulsation-Induced Shaking Forces (Unbalanced Forces)

Predict the maximum pulsation-induced shaking forces and unbalanced pressure acting on the critical elements of the piping system, such as pulsation control devices, pulsation control device internals, vessels, closed-end headers, and the like.

E.1.2.3. Development of Piping Modifications

If the pulsation analysis indicates that pulsation levels and/or shaking forces are excessive, modifications to the pulsation control devices and/or piping systems will be made and the analysis continued until the system meets the guidelines defined in 3.6.2.2 or other criteria as agreed upon by the purchaser and vendor.

E.1.3 MECHANICAL PIPING SYSTEM ANALYSIS

This study calculates the mechanical natural frequencies of the individual piping spans using published frequency factors, nomograms, computer simulation, and so forth to ensure that the piping span natural frequencies are detuned from significant pulsation excitation harmonics. From this analysis, the piping supports, clamp type, effective direction of restraint, and their locations are recommended. Thermal flexibility effects should be considered in the clamp designs and anchoring systems.

E.1.4 PUMP VALVE DYNAMIC RESPONSE STUDY

This study calculates dynamic response of the valve spring and sealing element, including interaction with the pump working barrel pressure and pump geometric parameters. It evaluates valve dynamic effects on pump dynamic flow characteristics, working barrel pressure, and valve impact characteristics.

E.1.5 PIPING SYSTEM FLEXIBILITY

This analysis predicts the forces and stresses resulting from thermal gradients, pipe and fitting weights, static pressure, and bolt-up strains, plus pump and component growths. These stresses are compared to the levels identified in the applicable ANSI specification.

E.2 Design Guidelines

Appendix F provides guidelines for pump piping design and preparation for an acoustical simulation analysis.

APPENDIX F—GUIDELINE FOR PUMP PIPING DESIGN AND PREPARATION FOR AN ACOUSTICAL SIMULATION ANALYSIS

F.1 General

F.1.1 Any reciprocating pump in conjunction with a piping system forms an interactive dynamic system that cannot be accurately analyzed as two separate systems. Therefore, it is very difficult for the pulsation system designer and the piping system designer to arrive at proposed designs on an independent basis that can be guaranteed to work in the final analysis and be cost effective.

F.1.2 Subsection 3.6.1 of this standard defines the technical requirements placed on the pulsation control system designer. This appendix gives guidelines for the piping system designer which may help to minimize problems that can occur at the time of the acoustical simulation, and outlines the information that must be available at the time of this interactive analysis. Communication between the piping system designer, the pump vendor, and the pulsation control device designer during the course of a project is important to minimizing problems and developing the best overall pump system installation. The key times of interaction are at the post-order coordination meeting early in the project and during the interactive acoustical simulation/mechanical analysis.

F.1.3 The purchaser may elect to perform an in-house acoustical simulation, use equipment vendor services, or use services of a third party.

F.2 Acoustical Considerations in Piping Designs

F.2.1 The interaction of the pump, pulsation control devices, and piping system produces potentially harmful pulsations when there is resonant interaction between the various elements in the system. The system designer can help to minimize this interaction by avoiding resonant lengths of constant diameter pipe for constant speed pumps. When resonant lengths of constant diameter pipe are used and the resonant frequency matches multiples of plunger frequency, one can expect major changes to the system as a result of the acoustical simulation analysis. The resonant length of various piping configurations is given in the following equation. It is recommended that lengths of these configurations be avoided in a ± 10 percent band for the first four harmonics of plunger frequency. The piping areas where this is most important are the sections of piping nearest the pump.

F.2.2 For piping sections open at both ends or closed at both ends, the length to be avoided can be calculated from the following:

$$L_H = \frac{30 \times C}{np \times N} \quad (\text{F-1})$$

Where:

- L_H = Pipe length to be avoided, in meters (feet).
- C = Velocity of sound in liquid, in meters/sec (ft/sec).
- n = Harmonic number (1, 2, 3, and 4).
- p = Number of plungers (3, 5, 7, 9, and so forth).
- N = Pump speed, in rpm.

Examples of this are lengths between major volumes, length of headers, and so forth.

F.2.3 For pipe sections open at one end and closed at the other end, the lengths are to be calculated from the following:

$$L_Q = \frac{15 \times C}{np \times N} \quad (\text{F-2})$$

Where:

- L_Q = Pipe length to be avoided, in meters (feet).
- C = Velocity of sound in liquid, in meters/sec (ft/sec).
- n = Harmonic number (1, 2, 3, and 4).
- p = Number of plungers (3, 5, 7, 9, and so forth).
- N = Pump speed, in rpm.

Examples of this are relief valve lines and bypass lines.

Note: Pipe diameter changing from a small to a larger size can be considered an open end when the diameter change is two to one or more. Similarly, pipe diameter changes from a large to a small diameter can be considered a closed end when the diameter change is two to one or more.

F.2.4 The design must be checked with an acoustical simulation after the piping design has been completed with the initial location of mechanical restraints, and the pipe thermal stresses are found to be in acceptable limits.

F.2.5 For variable speed pumps and/or those with varying velocity of sound, and for multiple pump installations, the separation of resonances is more difficult to calculate and can be handled properly only with an acoustical simulation study.

F.3 Acoustical Simulation Overview

F.3.1 The extent of the piping system to be analyzed by acoustical simulation techniques is usually defined as all the associated piping to a point where piping changes will have only insignificant effects on the parts of the system under study and in determining the acoustical characteristics of the design. Typically, these requirements are satisfied by beginning the simulation with the inlet of a major process vessel or volume on the suction side of the pump unit(s), and terminating the study at the outlet of a major process vessel or volume on the discharge side of the unit(s) or into an infinite line (sufficiently long that reflections will be attenuated to very low levels). Lateral lines to or from this system, such as

relief valve lines and bypass lines, should be included in the analysis.

F.3.2 When major volumes do not exist or are very remote from the pump, suitable piping lengths are included such that the pulsation levels are sufficiently low so as to minimize the potential of pulsation-driven vibration problems.

F.4 Information Required

F.4.1 THE COORDINATOR

The acoustical simulation requires a considerable amount of information in order to be properly performed. The purchaser, or his representative, normally serves as coordinator to see that the information is available.

F.4.2 INFORMATION FROM THE SYSTEM DESIGNER

F.4.2.1 A data sheet is required showing all pump operating conditions (speed, pressures, etc.) and all fluids to be pumped.

F.4.2.2 Isometric drawings are required showing all lengths (between bends, valves, diameter changes, and so forth) and line sizes and schedules for the complete piping systems, including all branch lines and safety valve lines. If a mechanical study is included, the distance between the supports and the type of support and clamp used at each location must be shown on the isometrics. A detailed drawing of each type of support and clamp is required.

F.4.2.3 Piping and Instrument Diagrams (P&IDs) are required to ensure that all piping and equipment that may affect the study are included.

F.4.2.4 Layout drawings are required to help determine the practicality of any proposed modifications. Reproducible drawings are useful since they can be marked up and copies included in the report.

F.4.2.5 Complete information must be supplied on all of the piping up to and including the first large volume in the suction and the discharge piping to a large vessel or to an acoustical infinite line. Every branch must be included up to a shutoff valve or a large volume.

F.4.2.6 Any orifice or other flow resistive device must be shown and complete details on pressure drop provided.

F.4.2.7 Detailed drawings of each vessel, showing the location of all nozzles, the internal diameter, and the length,

as well as details of any vessel internals are required. Design pressure drops in these vessels must be shown.

F.4.2.8 If there are different fluid routings, a complete description must be included to show the relative positions of all the valves for each routing. If different fluids are involved, the description must show which routings apply to which fluids. Flow from/to any sidestream must be shown, including fluid contents, flow rate, and direction.

F.4.2.9 When two or more pumps are connected to the same piping system, a clear description is required explaining how they will operate.

F.4.3 INFORMATION FROM THE PULSATION CONTROL DEVICE VENDOR

Information from the pulsation control device vendor should include detailed dimensional drawings on each pulsation control device showing the location of all nozzles, lengths, internal diameters, and details on internals, if any. Pulsation control devices with internal gas-charged bladders or gas blankets should clearly indicate the volume of gas and the charge pressure. The design pressure drop for the design flow should be specified. The pulsation control device vendor should supply sufficient information to characterize the effective spring and mass properties of any gas-charged elastomer bladder device.

F.4.4 INFORMATION FROM THE PUMP VENDOR

Information from the pump vendor is shown in the following Table F-1.

Table F-1—Information From the Pump Vendor

Pump Data	Design Approach	
	1	2
Pump Data		
Pump Cylinder (Internal Passages)	x	x
Pump Geometric Data (Bore, Stroke, RPM)	x	x
Pump Valve Data		
Type of Valves		x
Valve Lift		x
Weight		x
Spring Pre-Load		x
Spring Rate		x
Full Projected Area		x
Lift Area		x
Effective Full Lift Flow Area		x

APPENDIX G—NET POSITIVE SUCTION HEAD VERSUS NET POSITIVE INLET PRESSURE

Because centrifugal pumps and positive displacement pumps operate on entirely different principles, common usage has created two different ways to identify the pressures associated with them. In its simplest form, a centrifugal pump is a velocity machine. The liquid to be pumped is directed into the center of a rotating impeller where it is entrained in the impeller vanes and accelerated to a higher velocity. The casing surrounding the impeller then converts the high velocity into pressure. Because it is a velocity machine, if pressure is measured in units of liquid length, all units of measure become consistent. Velocity is measured in meters/second (feet/second) and pressure is measured in meters (feet), i.e., the pressure created by the height of a column of the liquid being pumped. This consistent use of units greatly simplifies pump calculations and allows the effects of certain liquid properties (specific gravity, for example) to be ignored.

By contrast, a positive displacement pump does not generate pressure solely by increasing fluid velocity. Instead these pumps convert rotating motion and torque into linear fluid motion and force, generating variable flow at the discharge connection. Positive displacement pumps have no theoretical discharge pressure limitation. They respond solely to the pumping system, and require system discharge control, usually in the form of a relief valve, to prevent damage to the pump mechanism and/or stalling of the driver. A centrifugal pump, however, responds quite differently in that the discharge pressure developed is a function of flow through the pump impeller. With decreasing flow (as in the case of increased system resistance) the centrifugal pump develops an ever increasing pressure rise up the point defined as the shutoff head at zero flow. Shutoff head is the maximum pressure rise that a centrifugal pump can develop. For a positive displacement pump, flow is a function of pump stroke and/or rpm.

Either type of pump requires sufficient fluid pressure at the inlet to prevent a release of dissolved gases and/or a change of the state of the pumped fluid from liquid to gas. The term for pressure at the inlet is either *Net Positive Suction Head (NPSH)* or *Net Positive Inlet Pressure (NPIP)*. To be consistent, the API standards for both centrifugal and reciprocating pumps, as well as the latest editions of the Hydraulic Institute standards refer to the total suction head as *NPSH* rather than *NPIP*. Although the Hydraulic Institute indicates that *NPSH* is normally expressed in either kilopascals (pounds per square inch) or meters (feet), the latest API standards refer to *NPSH* in meters (feet), the preferred unit terminology for both pump types, to avoid confusion. Positive displacement pump manufacturers generally refer to *NPIP*, expressed in kilopascals (kPa) [pounds per square inch (psi)].

NPSH or *NPIP* is indicated as either *Available* or *Required*. The Net Positive Inlet Pressure Available is the absolute pressure above fluid vapor pressure at the pump inlet and is determined as follows:

$$\text{NPIP Available} = P_a + P_z - P_f - P_{vp} - P_{ha}$$

Where:

- P_a = absolute pressure at surface of liquid, in kPa abs (psia).
- P_z = static head (+) or static lift (–), in kPa (psi) for level of fluid above or below inlet.
- P_f = inlet line, valve, and fitting friction losses at maximum viscosity, in kPa (psi).
- P_{vp} = fluid vapor pressure or gas dissolution pressure, in kPa abs (psia).
- P_{ha} = pressure loss due to acceleration head (see below), converted to kPa (psi).

NPIPA calculation for a reciprocating power pump must include the effects of system acceleration head. This is the head required to accelerate the liquid column on each suction stroke so that there will be no separation of this column in the pump or suction line. From the *Hydraulic Institute Standards*, Fourteenth Edition, the head required to accelerate the fluid column is a function of the length of the suction line, the average velocity in this line, the rotative speed, the type of pump, and the relative elasticity of the fluid and the pipe. For short suction lines, acceleration head may be calculated as follows:

$$h_a = \frac{LVn^2C}{Kg}$$

Where:

- h_a = acceleration head, in meters (feet).
- L = length of suction line, in meters (feet).
- V = velocity in suction line, in m/s (fps).
- n = pump speed in rpm.
- C = 0.400 for simplex single-acting.
= 0.200 for simplex double-acting.
= 0.200 for duplex single-acting.
= 0.115 for duplex single-acting.
= 0.066 for triplex single or double-acting.
= 0.040 for quintuplex single- or double-acting.
= 0.028 for septuplex single or double-acting.
- K = a factor representing the relative compressibility of the liquid. ($K= 1.4$ for hot water; $K= 2.5$ for hot oil.)
- g = gravitational constant 9.82 m/s^2 (32.2 ft/sec^2).

Note: The constant C will vary from these values for unusual ratios of connecting rod length to crank radius.

It is the responsibility of the purchaser to define the acceleration head (1.4.16), yet the value is dependent on the characteristics of the pump selected. Consequently, the value should be reviewed by both the purchaser and the vendor before a final selection is made.

NPiP Required is a function of pump type, speed, and viscosity of the fluid pumped. NPiP Available must always be greater than NPiP Required to prevent the occurrence of cavitation. Typically, NPiP Required values published by positive displacement pump manufacturers are expressed in kPa (psi) units.

API STD*674 95 ■ 0732290 0546105 072 ■

1-01400-6/95-1.1M (1E)

American Petroleum Institute
1220 L Street, Northwest
Washington, D.C. 20005



Order No. 822-67402